

Obtaining a permit for your Best Barns or Sentry Buildings kit.

Building code offices and HOA's may require different documents to obtain a permit. The homeowners first step is to contact their local code office and ask what is needed for the size of building to be purchased.

Typically, the necessary documentation may include some or all of the following.

- Elevations showing at least two sides of structure.
- Site plan showing existing structures and proposed build site.
- Engineered drawings for truss system indicating snow and wind load ratings.*
- Cross sections of wall framing and foundation.
- Tie down locations for high wind load areas.

Permit requirements vary based on location. Some areas may not require a permit at all. The documents provided by Best Barns or Sentry Buildings are intended to help the homeowner with the permit process but do not guarantee a permit will be issued.** It is the homeowner's responsibility to determine if a permit is required and submit the necessary documentation if so.

* Engineered truss drawings stamped for your individual state can be obtained upon request. A deposit will be required if shed or garage kit has not yet been purchased. Contact us directly at 800-245-1577 for further details.

** Certain states such as Florida and California have stringent requirements for obtaining a permit. Depending on your location, a civil engineer's services may be required to provide necessary documents. These services are the homeowners responsibility to obtain and are not included in the purchase of a shed or garage kit.



Before you order our kit or begin construction, obtain a building permit. If additional documents are required contact questions@barnkits.com.

TAHOE ELEVATION

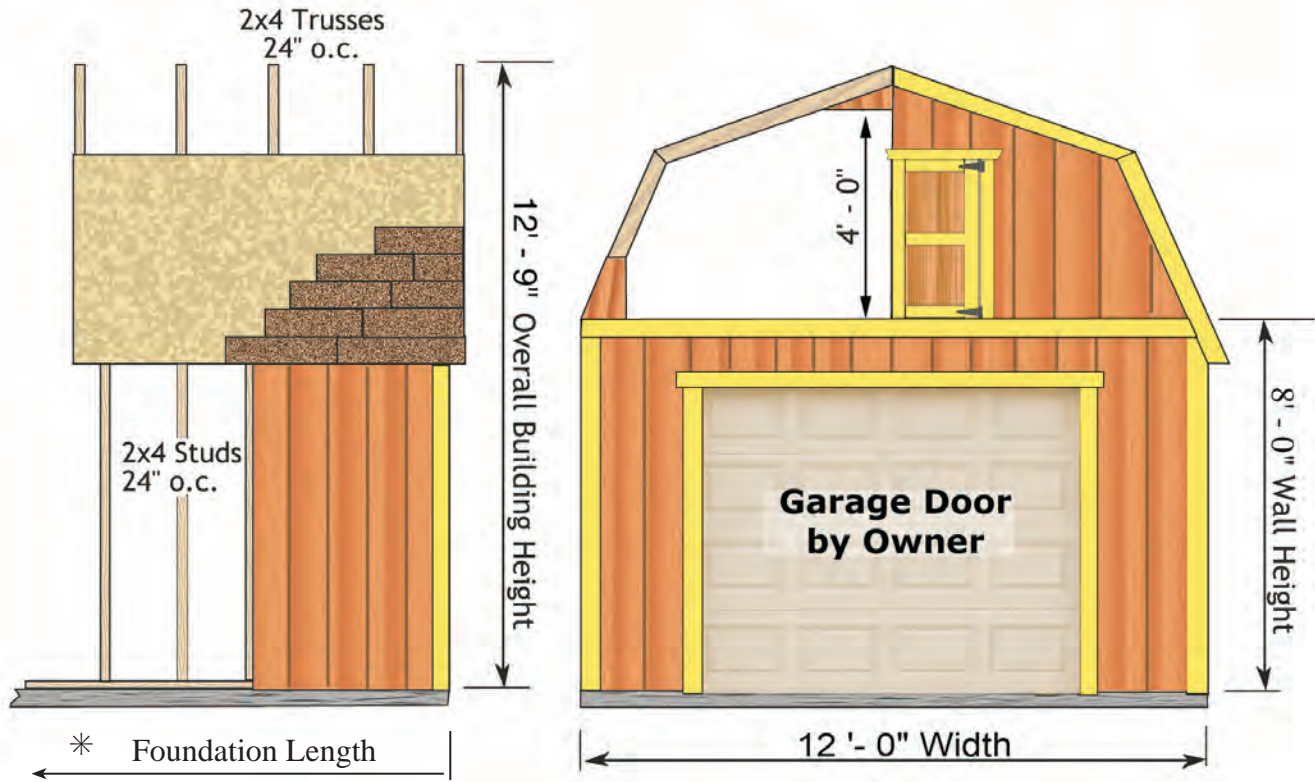

Wall Framing: Constructed from 2x4 pre-cut wall studs spaced 24" o.c. Bottom plate, top and tie plate. Door Header is a 2x10.

2nd Loft Floor: Loft floor on each end with a 4' wide access opening between loft sections. A 42" x 36" high loft door opening on front gable.

Siding: Louisiana-Pacific 'SmartPanel' 8" o.c. groove, primed ready to paint

Roof System: 2x4 trusses spaced 24" on center. 7/16" OSB roof sheathing. *Shingles by owner.*

Exterior Trim: White pine door jamb, trim for door opening, gable trim and sidewall fascia.

Garage Door: By Owner.

Floor: Sold optionally.

Hardware: Nails for framing, metal hurricane hangers for trusses.

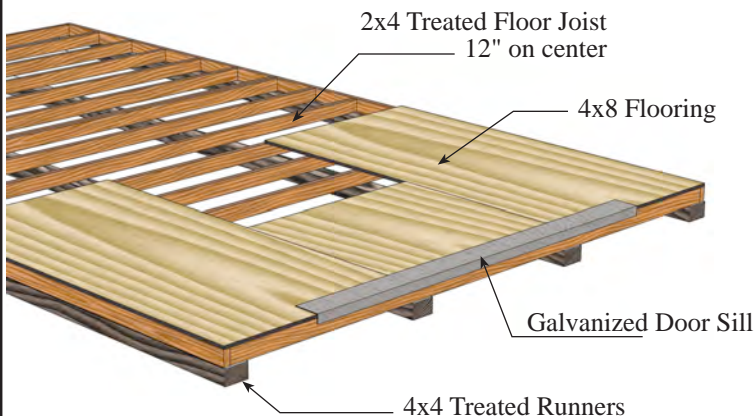

Optional Sturdy-built Floor System:

2x4 treated floor joist spaced 12" on center covered with 3/4" plywood, *not treated*, installed over 4x4 treated runners. Galvanized door sill and nails are included. Material is not pre-cut.

- * 12'x16' Foundation Size 12'-0" x 16'-0"
- 12'x20' Foundation Size 12'-0" x 20'-0"

Best Barns model: _____
____ft. wide x ____ft. long

Manufactured by:
Reynolds Building Systems, Inc.
205 Arlington Drive
Greenville, PA 16125
phone: 800-245-1577
fax: 724-646-0772

Common Foundation Cross Sections

This document illustrates common foundation types which can be used for construction of Best Barns 12 ft. wide structures. Alteration may be necessary to conform to homeowners intended use and or permitting requirements.

Drawings not to scale.

Instructions:

Check appropriate foundation cross section and provide specifications as necessary.

Homeowner may also design and draw in space provided for custom foundation type.

Concrete Slab

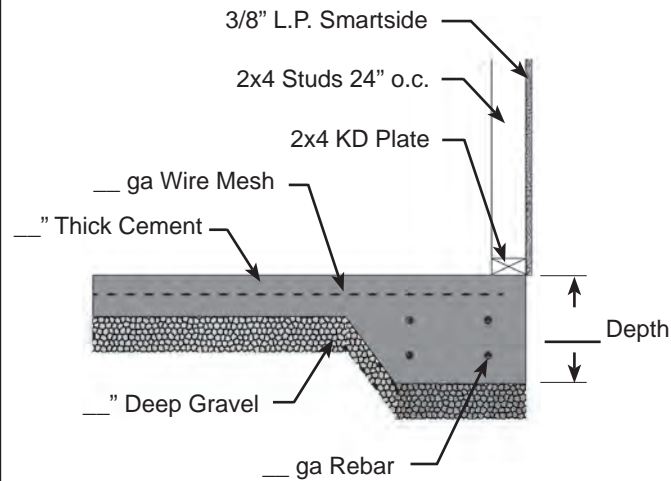

Wood Floor

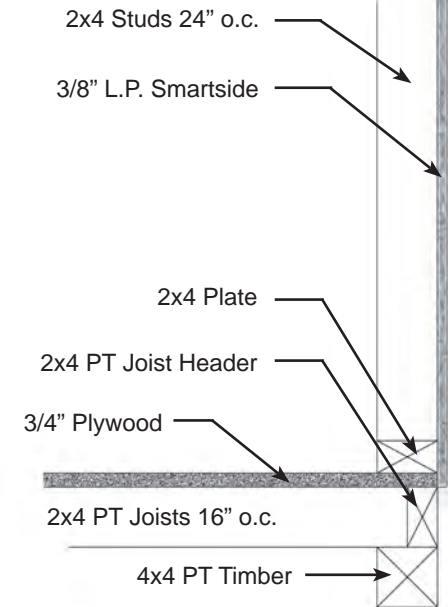

Homeowner Design

Best Barns model: Millcreek
12ft. wide x ___ ft. long

Manufactured by:
Reynolds Building Systems, Inc.
205 Arlington Drive
Greenville, PA 16125
phone: 800-245-1577
fax: 724-646-0772

Truss & Wall Cross Section

Top of wall inclusive of wall framing, loft floor, floor joists, joist header and truss cross sections.

Drawing not to scale.

Instructions:

Homeowner may provide additional information as appropriate.

Notes:

Refer to installation manual for further detail.

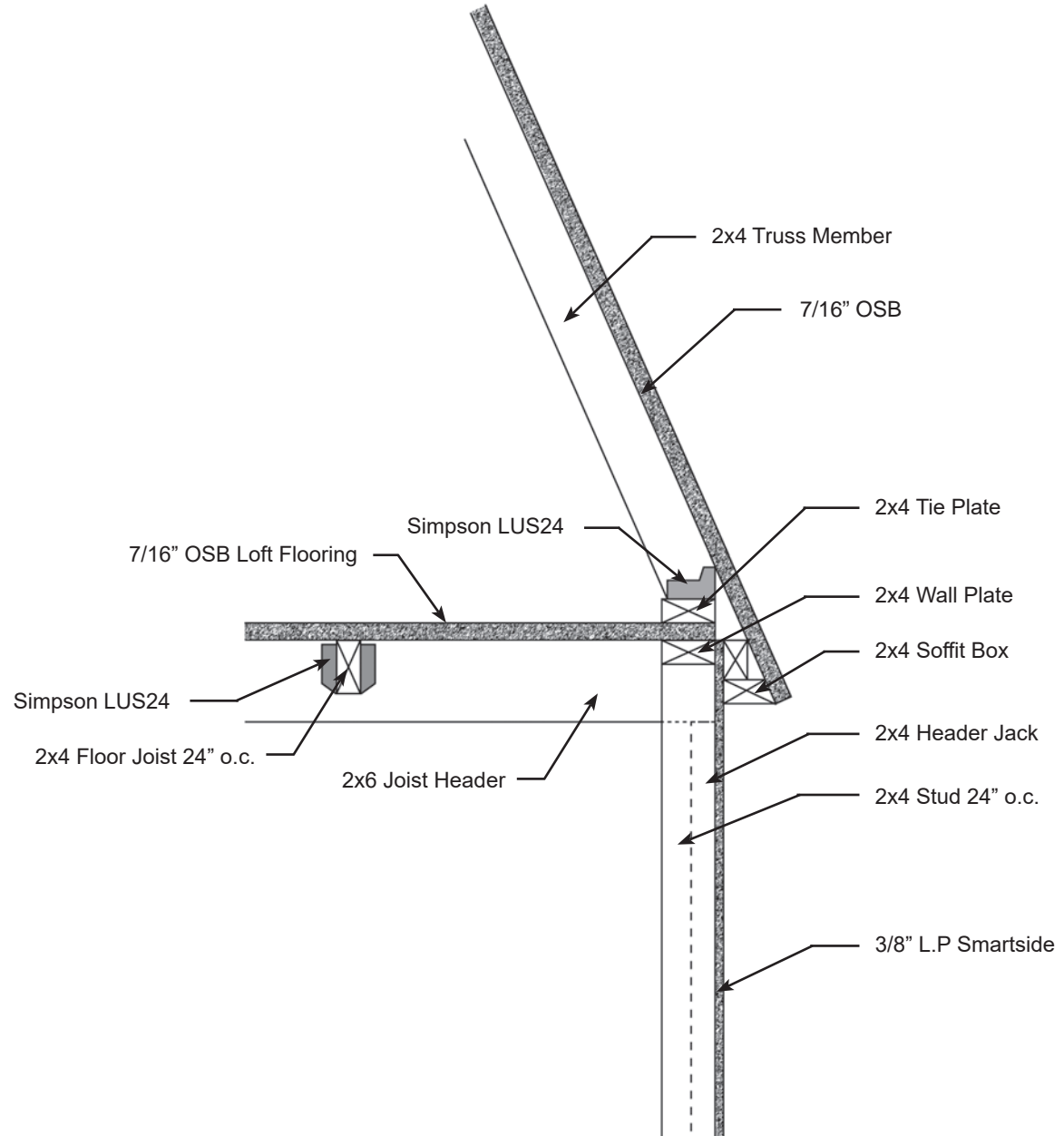

Site Plan for:

Manufactured by:
Reynolds Building Systems, Inc.
205 Arlington Drive
Greenville, PA 16125
phone: 800-245-1577
fax: 724-646-0772

Instructions:

Draw property line, existing structures and proposed placement of building.

Homeowner may also be required to show trees and shrubs. Check with HOA or permit office for requirements.

