



Best Barns USA Assembly Book

Revised September 19, 2017



the Fairview

Building Size 12'x16'

Manufactured by Reynolds Building Systems, Inc.

205 Arlington Drive Greenville, PA 16125

This manual is copyrighted. Under the copyright laws, this manual may not be copied, in whole or in part, without consent from Reynolds Building Systems, Inc. © Copyright 2011

IMPORTANT INFORMATION ABOUT YOUR SHED KIT

Download the most current instruction book at www.barnkits.com; use the "manuals" link on the menu bar and then select your building kit and size.

If you have any questions about assembling the kit, call 800-245-1577. If you are calling after normal business hours, call 724-866-HELP (4357) or email to help@barnkits.com.

The material that is included in our kit is listed on the back page. The optional floor package, *if ordered*, will be supplied by a local lumber supplier.

Our kit does not include the shingles, the quantity needed is listed on the back page. The siding is primed. You will need to apply a finish coat using latex acrylic paint.

Our framing lumber is imported to provide you the highest quality available. However, if you need to replace any lumber for any reason please do so and we will reimburse you.

Our deluxe kit includes barn doors that have been pre-built. The siding and roof sheathing has also been pre-cut for easy assembly.

IMPORTANT: Unpack the material from the pallet, then unscrew the bottom 2x4s from the pallet runners. The bit for the screws is packed in the hardware bag. Remove the OSB panel from the sheet goods pallet, it will be used for roof sheathing.

Stacking the boards, according to size, will make them easier to find when needed. Some boards may have colored ends. **Do Not** discard any material until your building is complete.

Before you begin construction, be sure to study this assembly manual. Also, obtain a building permit and check all pertinent building code regulations.

Thank you for your purchase.

Bill & Linda Rinella, owners

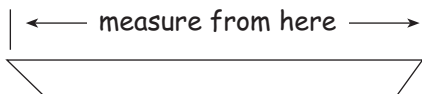

When measurements are given for a board length or width, it is from the longest side.

Tool List

- | | |
|---|--|
| <input type="checkbox"/> Hammer & Hand Saw | <input type="checkbox"/> Power Drill/screwdriver |
| <input type="checkbox"/> Framing Square & Level | <input type="checkbox"/> Measuring Tape |
| <input type="checkbox"/> Power Circular Saw | <input type="checkbox"/> 2 - 8' Step Ladders |

Always wear safety glasses when cutting or nailing!

Constructing Details for Deluxe Floor System

Deluxe floors include 4x4 runners, standard floors do not

Check local building codes in your area, the construction may have to change. For a concrete slab, install sill sealer as a moisture barrier between the concrete and the wall plates. Foam sill sealer can be purchased at home centers in rolls 3-1/2" or wider.

1. Cut (2) two 2x4 joist headers to 16' - 0". Layout for 16" on center joist spacing. 'X' marks where floor joist will be placed.

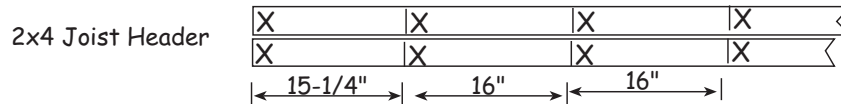

2. Cut 2x4-12' floor joist to 11'-9". Treated lumber may be thicker than 1-1/2". Take this into account when cutting the length of floor joists. Shorten joist measurements if necessary to obtain 12'-0" building width.

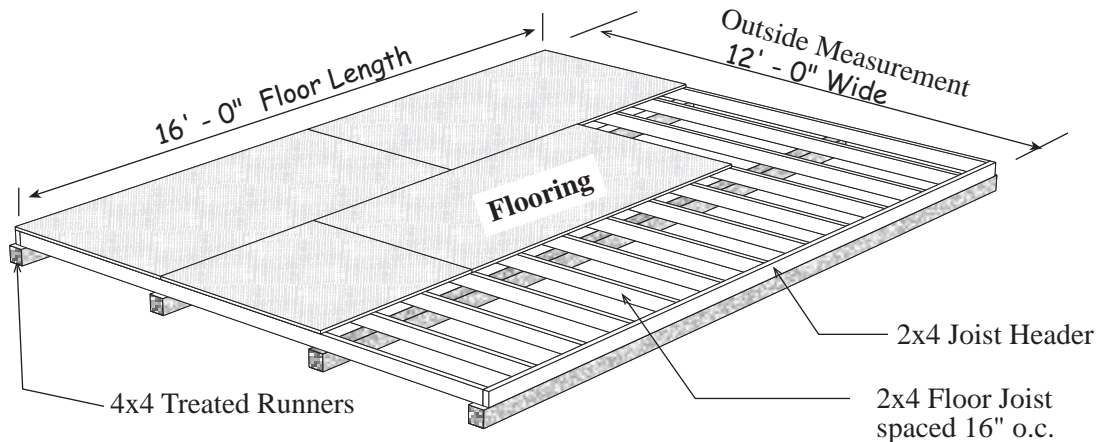

It is important that the floor be level and square. Square the floor as follows: before nailing the flooring, measure the floor diagonally (corner to corner). Then measure the opposite corners. These measurements will be the same if the floor is square.

Material Description	12' x 16' shed
2x4 Joist Headers	2 pcs. 16'
2x4 Floor Joist	13 pcs. 12'
4x4 Treated Runners	8 pcs. 8'
Flooring 5/8" or 3/4"	6 pcs. 4x8
Screw Floor Nails	2 lb. 8d
Galv. Box Nails	2 lb. 16d

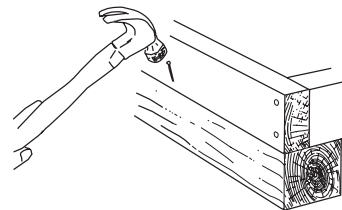

Nail 2x4 joist headers and floor joist to 4x4.

Step 1 Assemble Trusses

 **Building Tip:** To aid in the assembly of the trusses, temporarily screw 2x4 blocks to the floor. There are short 2x4s, *that may have an angle on one end*, supplied in kit.

1. Screw (2) two 2x4 blocks to the 12' wide end of the floor at the top corner, *see below*.
2. Place two truss legs together. Position the notch in the 2x4s (called a bird's mouth) into the 2x4 blocks. **Important:** You must have 12'-0" between the bird's mouth. Affix more 2x4 blocks above the truss legs to hold the truss members in place.
3. Secure the tops together with a wood gusset. Apply wood glue between the 2x4 boards and the gusset. Nail the gusset to the 2x4s with 6d common nails. Use 14 nails per gusset.
4. Install a 2x4-90° collar tie between the 2x4 boards. Hold in place with 2x4 blocks. Install 12"x24" gussets to the ends of the collar tie. Glue and nail using 14 nails per gusset.
5. Turn this truss over and apply wood gussets to the opposite side.
6. Repeat 2 through 5 to assemble (6) six more trusses.

Do Not remove blocks from floor until completing **Step 2**.

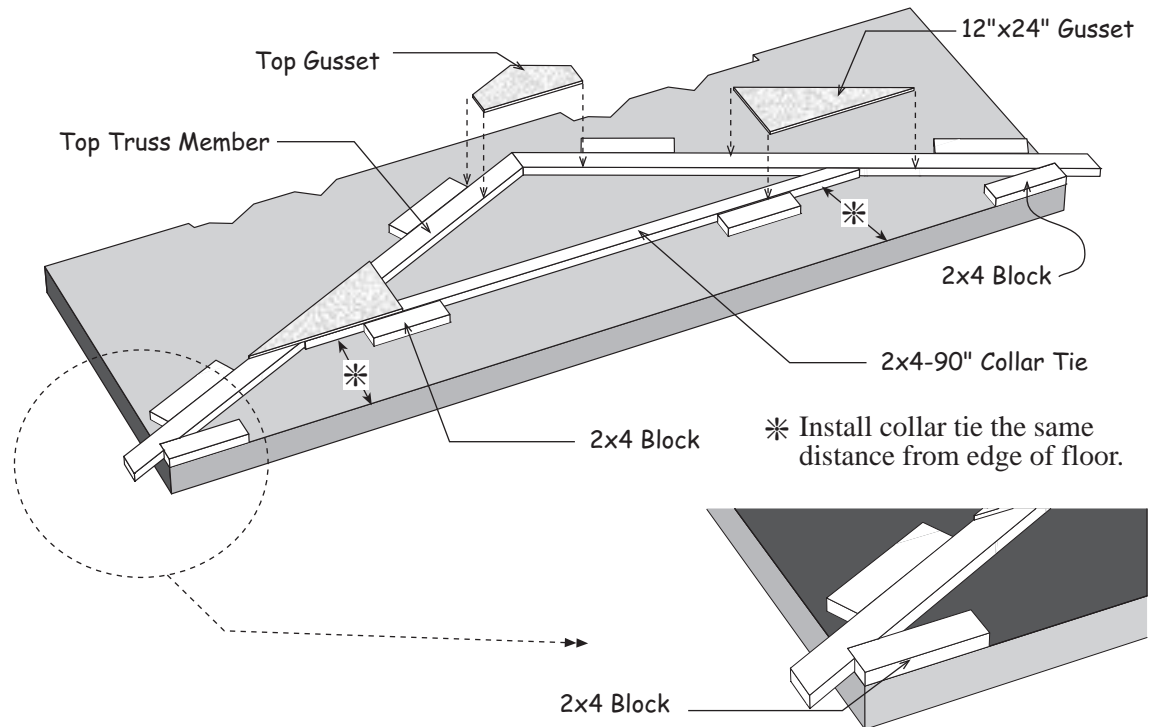

Step 2 Assemble Roof Gables

1. Butt (2) two 72" long 2x4s together and secure by nailing a 3-1/2" x 31-3/4" long plywood gusset across the top where they butt together. Use glue and 6d common nails.

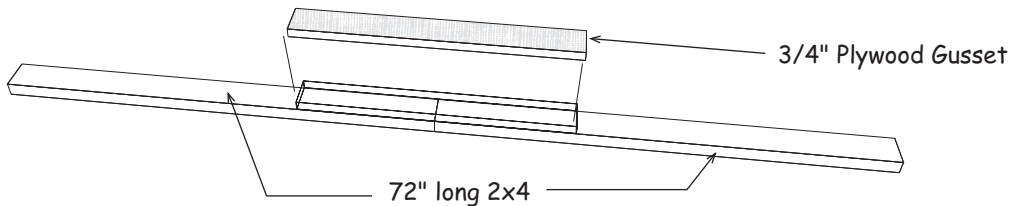

2. Place (2) two truss members in the jig. Secure the top together with a barbed metal plate.
3. Remove the 2x4 blocks at the corners of the floor and insert the gable plate assembled above into the bird's mouth. Make sure the 2x4 gable plate is straight. If necessary, tack 2x4 blocks to hold plate straight.

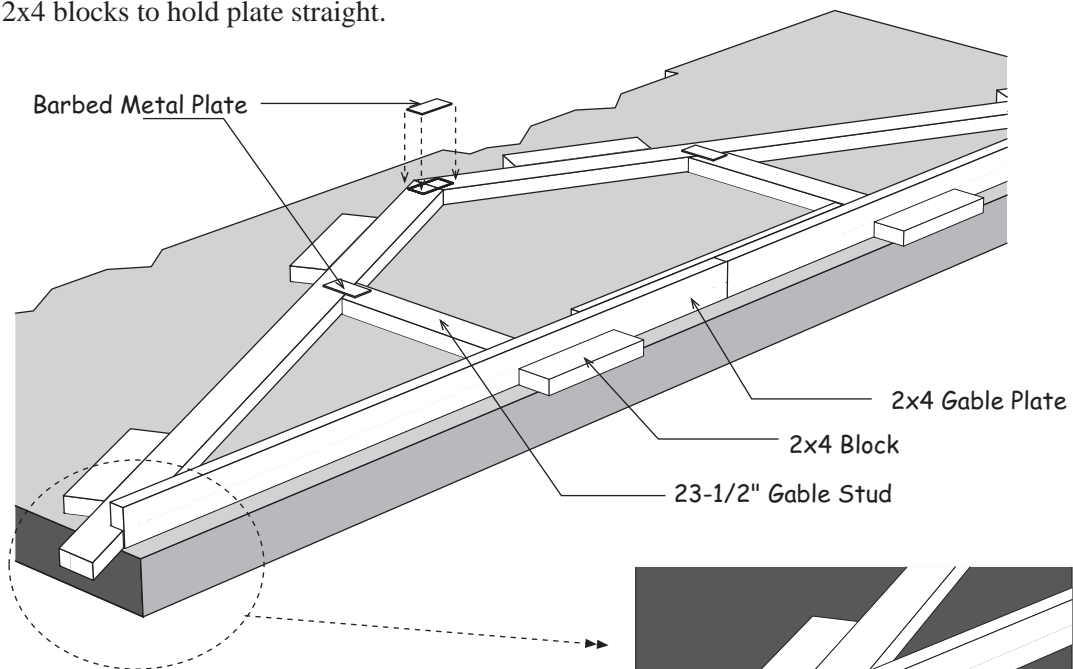

Screw gable plate to truss leg with 2-1/2" screw.

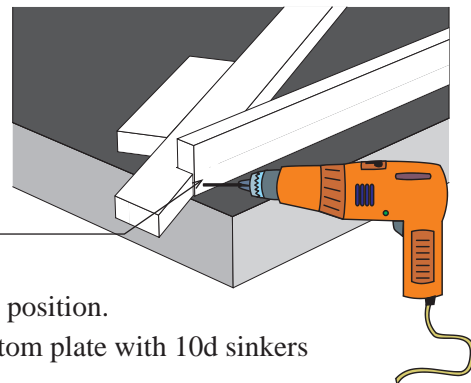

4. Remove the two 2x4 blocks that held the collar tie in position.
5. Install 2x4x23-1/2" gable studs. Nail through the bottom plate with 10d sinkers and secure the top with barbed metal drive-on plates.
7. Repeat to assemble another gable. Remove 2x4 blocks.

Step 3 Install Siding on Gables

1. Select one of the gable frames, Turn the gable over letting the bottom plate overhang the floor so the gable lays flat.
2. Install gable siding using 6d galv. nails across the top of the gable frame. Use 8d galv. nails along the bottom edge. See Note Below. *

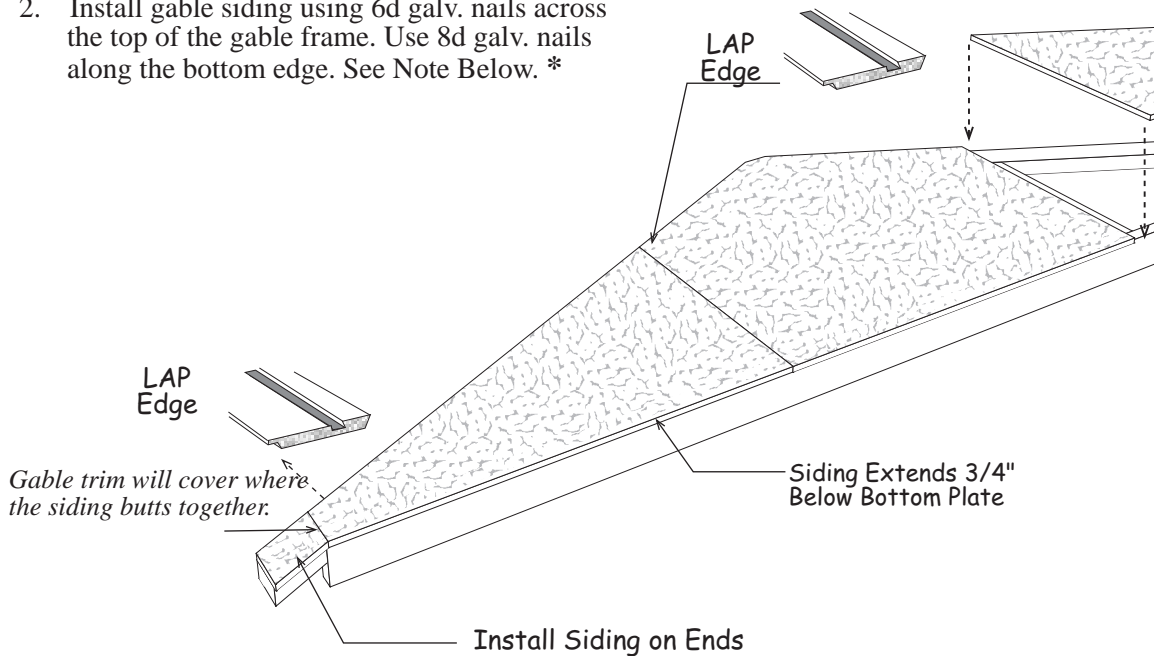

3. Install siding on the other gable frame.

* Exterior Siding

The siding is made in 4x8 sheets with grooves cut into the face, the long edge is beveled so that the siding overlays where they butt.

To identify which edge we want you to use, we will refer to the edge as either the 'LAP' Edge or the Tongue Edge. Nail siding with 8d galvanized box nails spaced 8" apart.

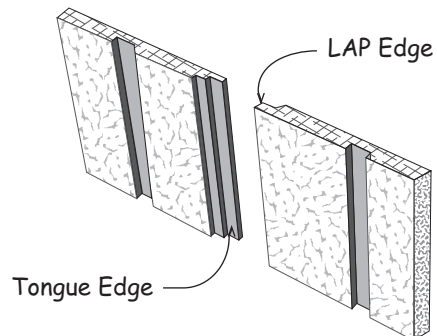

Step 4 Assemble 12' Back Wall

1. Position 2x4-72" boards together and indicate with 'X' marks, where the wall studs will be located.

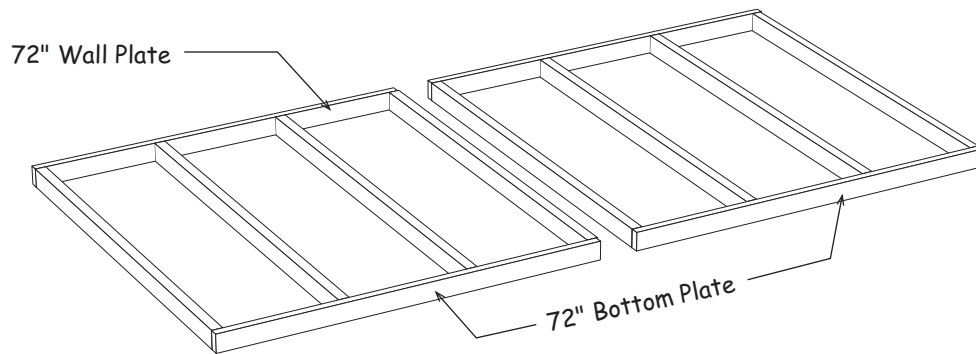
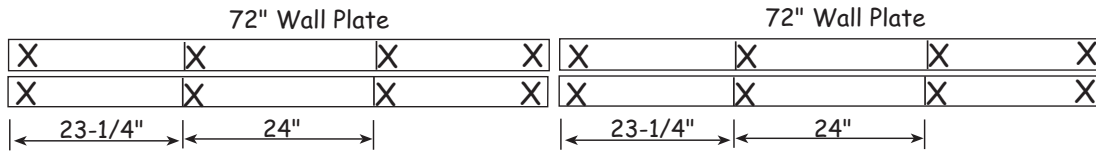

2. Install 72" wall studs between the top and bottom plates. Nail both wall frames together.
3. Square wall frame. *Measure diagonally (corner to corner). The measurements will be the same when the wall is square.*
4. Install the first siding panel with the 'LAP edge' flush with the end of the wall and extending 3/4" below the bottom plate.
5. Install (2) two more siding panels.

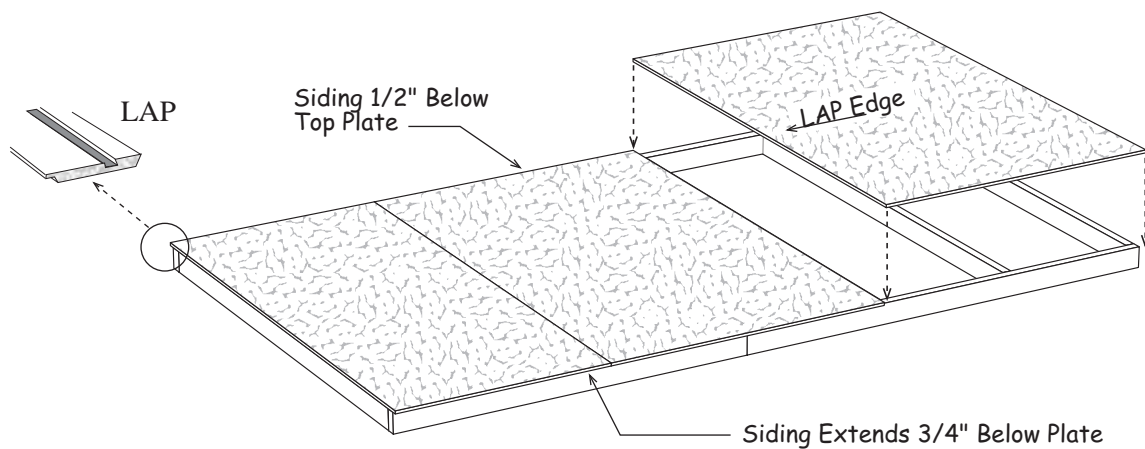

Step 5 Assemble 12' Long Sidewalls - No Doors

1. Position 68-1/2" and 48" long 2x4 boards together and indicate with 'X' marks, where the wall studs will be located.

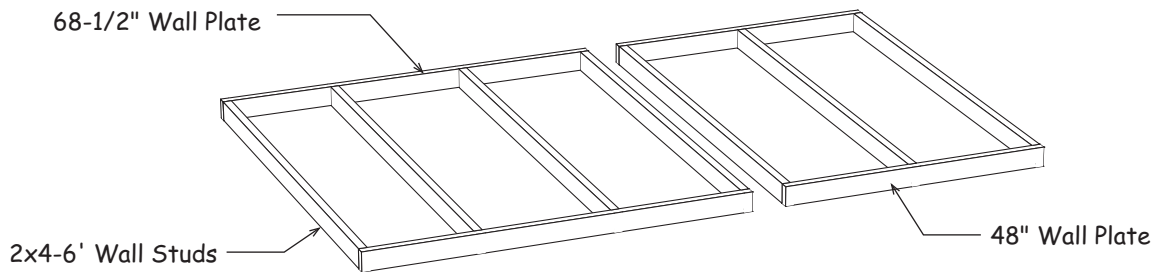
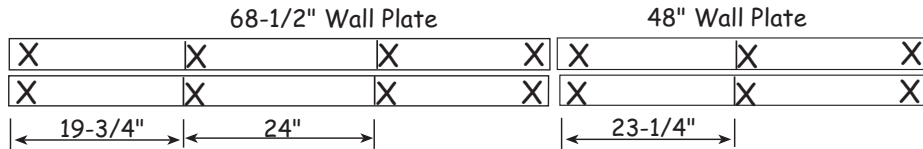

2. Install 72" wall studs between the top and bottom plates. Assemble wall frames with 10d sinkers, two (2) nails at each stud end. Nail both wall frames together.
3. Square wall frame. *Measure diagonally (corner to corner). The measurements will be the same when the wall is square.*
4. Cut a siding panel in half lengthways. Select the panel with the 'LAP' edge.
5. Install this siding panel with the 'LAP' edge extending 3-1/2" past the wall frame. The bottom will extend 3/4" below the bottom plate. Use 3/4" trim board as a gauge.
6. Install the other siding panels.

The siding will be 1/2" below the top of the wall frame on all walls.

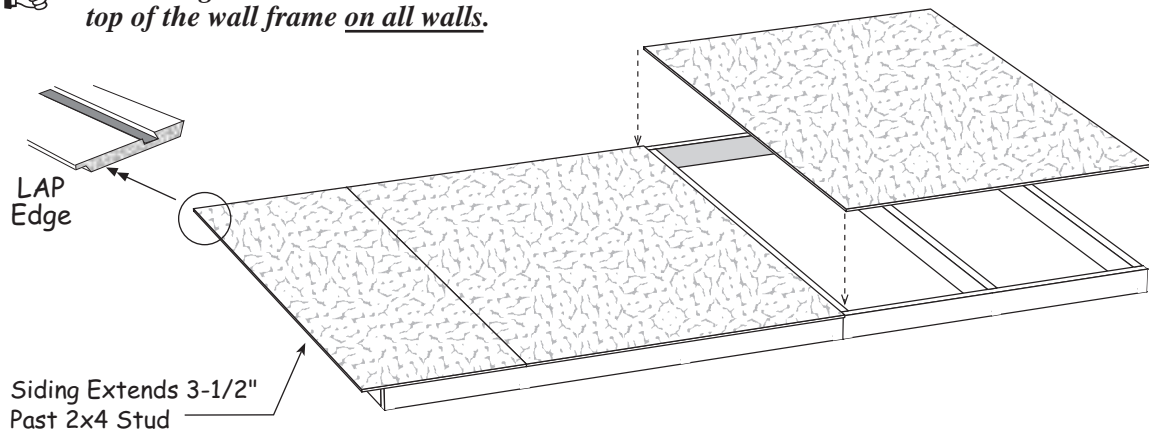

Step 6 Assemble Sidewalls - No Doors

1. Position 68-1/2" long 2x4 boards together and indicate with 'X' marks, where the wall studs will be located.

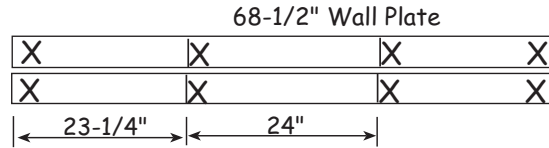

2. Install 72" wall studs between the top and bottom plates.

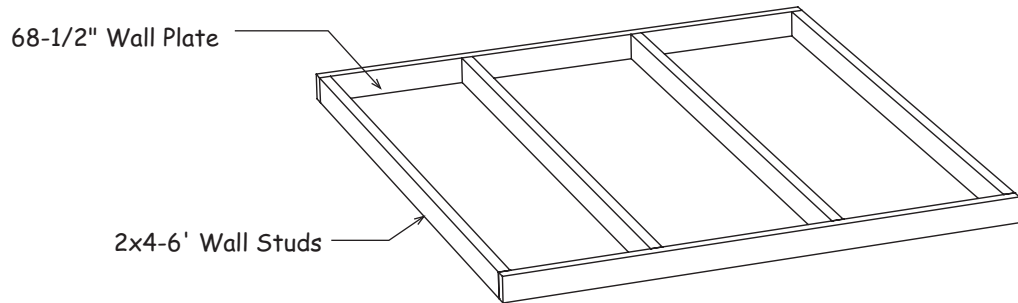

3. Select the 12' sidewall assembled in **Step 5**. Butt the wall frame, *assembled above*, against the wall with siding. **DO NOT** nail these frames together so they can be separated later.
4. Install a full width siding panel but do not nail along the long edge that overlaps the 12' wall frame. You can nail this edge after the wall panels are installed. This will enable you to separate the wall panels making them easier to handle.
5. Install the 24" siding panel, *cut in previous step*, last. It will extend 3-1/2" beyond the wall frame.

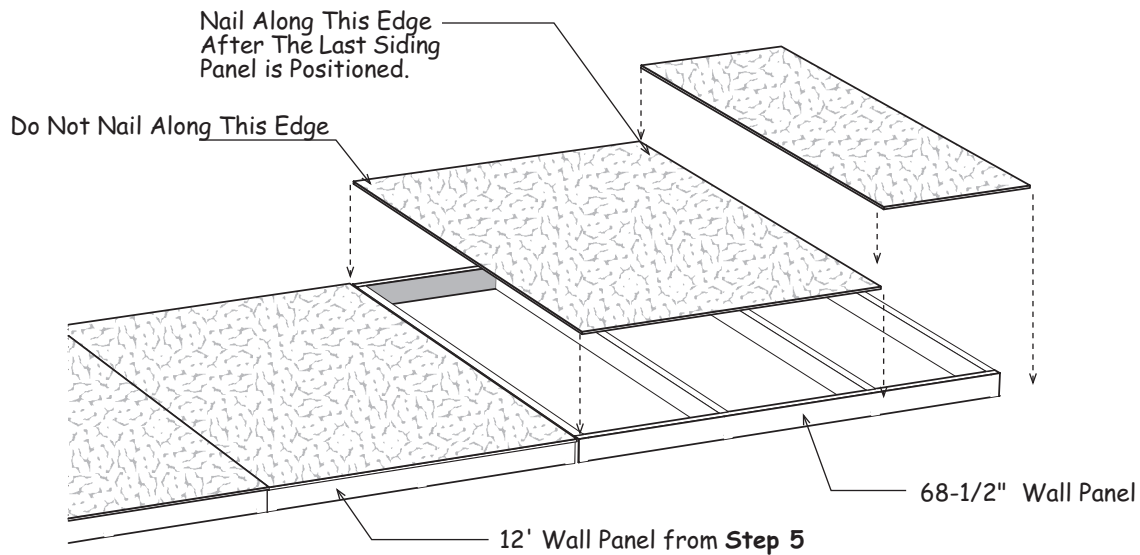

Step 7 Assemble Front Wall - Single Door

1. Cut (4) four 72" long 2x4s to a length of 54-1/4" to be used for top and bottom wall plates.
2. Install (5) five 72" wall studs between the wall plates.
3. Install a 71-1/2" long 2x4 as a header support on each wall frame. The 2x4s are packed in the door carton.

54-1/4" Wall Plate

4. Repeat steps to assemble another wall frame.

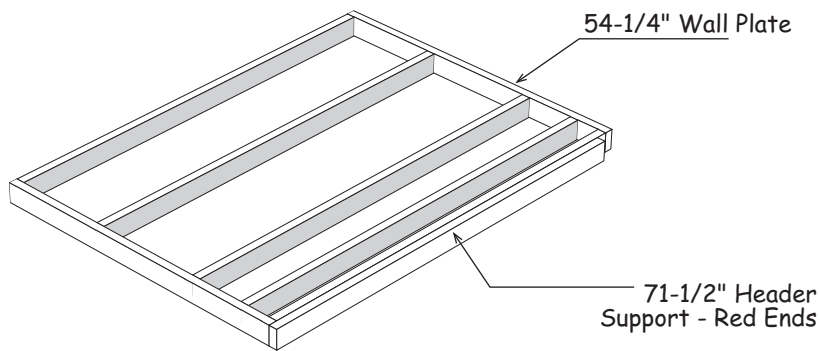
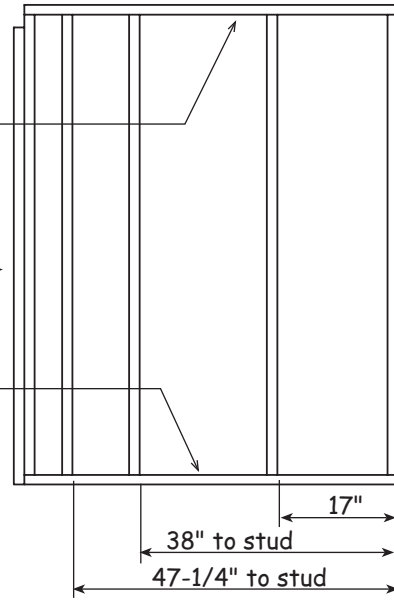

5. Nail (2) two 35-1/2" long 2x4 together with a OSB filler panel between them. Use 10d sinkers.

35-1/2" Long 2x4

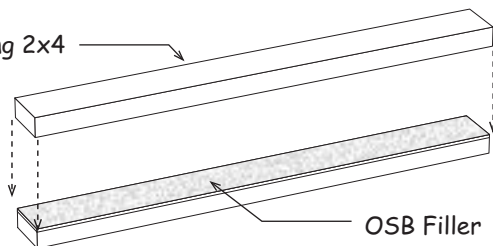

This material is packed in door carton.

Step 7 Assemble Front Wall - Single Door Continued

 The siding is packed in the door carton.

7. Install a full width siding panel. If you are installing windows you can cut the opening now or after the building is erected.

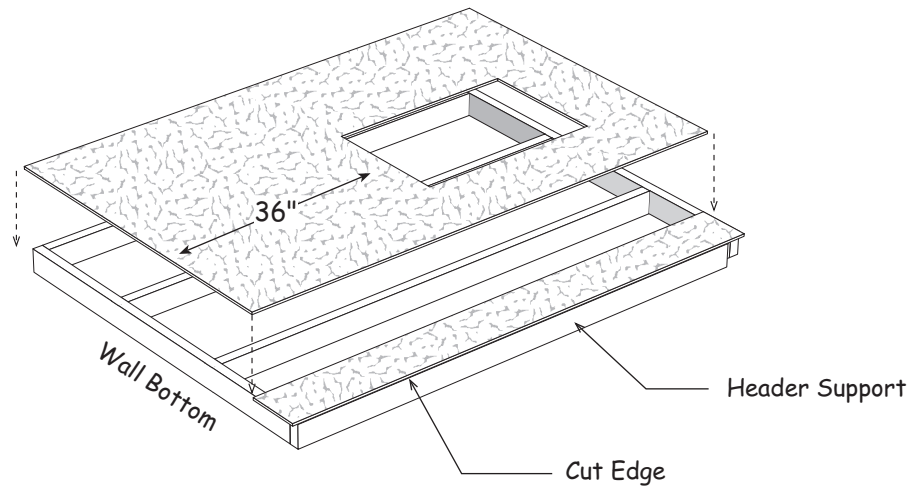

8. Install a 9-1/4" wide panel with the cut edge flush with the 2x4 header support. Install a full width siding panel last.

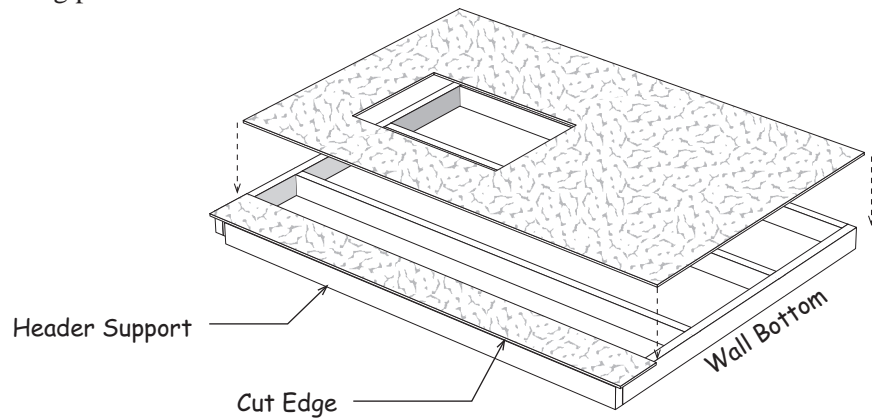

If you want the doors on the sidewall to be centered in the wall, proceed to **Step 8**. If you want the doors offset, as shown on the front cover, go to **Step 9**.

Step 8 Assemble Sidewalls - Double Doors Centered

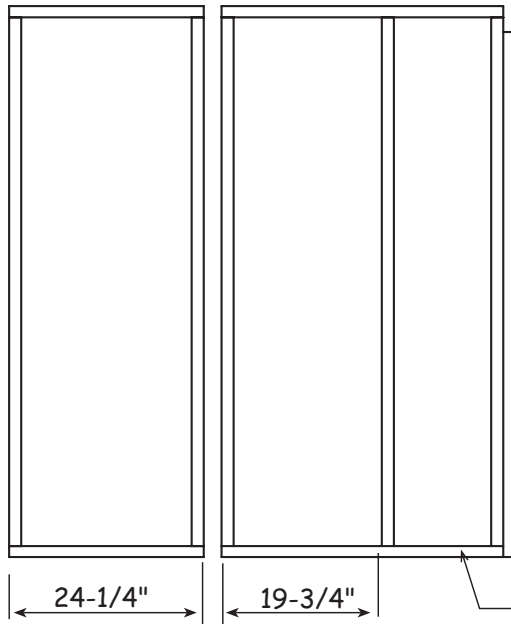

1. Locate (2) two 2x4-4' boards. Cut these boards to a length of 24-1/4".
2. Assemble a 2' wall frame with the plates cut above and (2) two wall studs. Use 10d sinkers.
3. Assemble another wall frame using (3) three 72" wall studs and (2) two 34-3/4" long 2x4 wall plates.
4. Install a 71-1/2" long 2x4 [red end], as a header support.

71-1/2" Header Support - Red End

34-3/4" Bottom Plate

5. Locate a 16" wide siding panel that has a 'LAP' edge. Position this panel with the 'cut' edge flush with the 2x4 header support and extending 3/4" below the bottom plate. Do not nail along the LAP edge until the other siding panel is installed.
6. Install a full width panel. The 'LAP' edge will extend 3-1/2" beyond the end of the frame. The siding should extend 3/4" below the bottom plate.

LAP Edge Extends 3-1/2" Beyond Frame

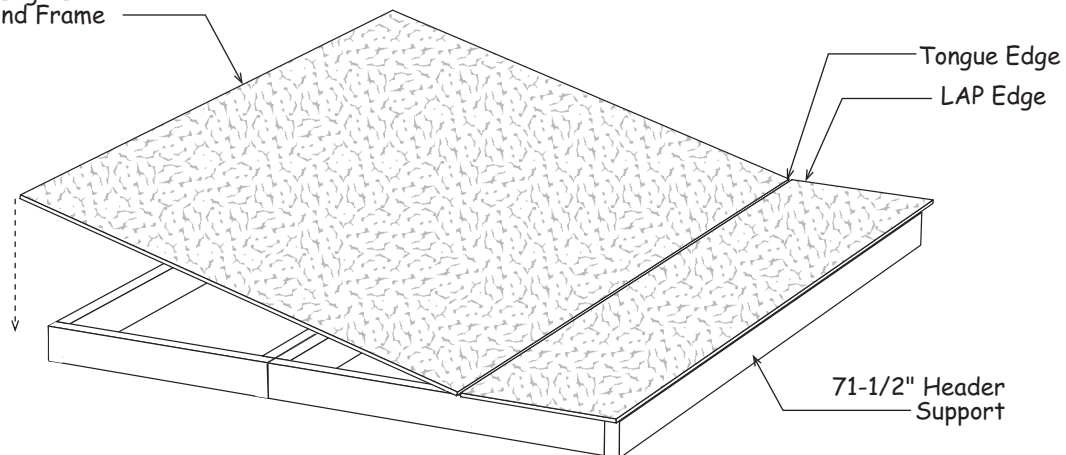

Step 8 Assemble Sidewalls - Double Doors (continued)

1. Assemble a wall frame using (4) four 72" wall studs and (2) two 58-1/2" long 2x4 wall plates. Use 10d sinkers.
2. Install a 71-1/2" long 2x4 as a header support.

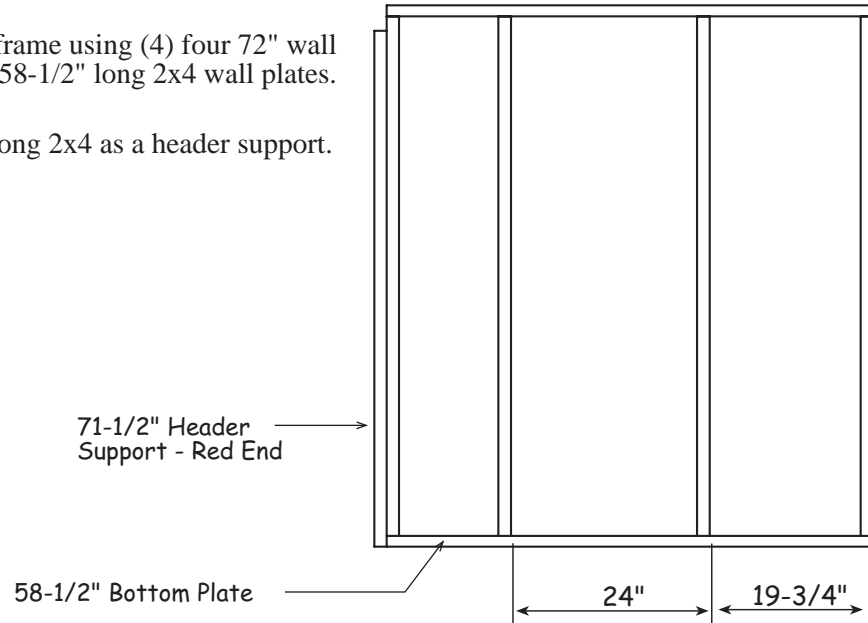

3. Install a 16" siding panel with the cut edge flush with the side of the door opening.
4. Install a full width siding panel. The siding will extend 3-1/2" beyond the frame.

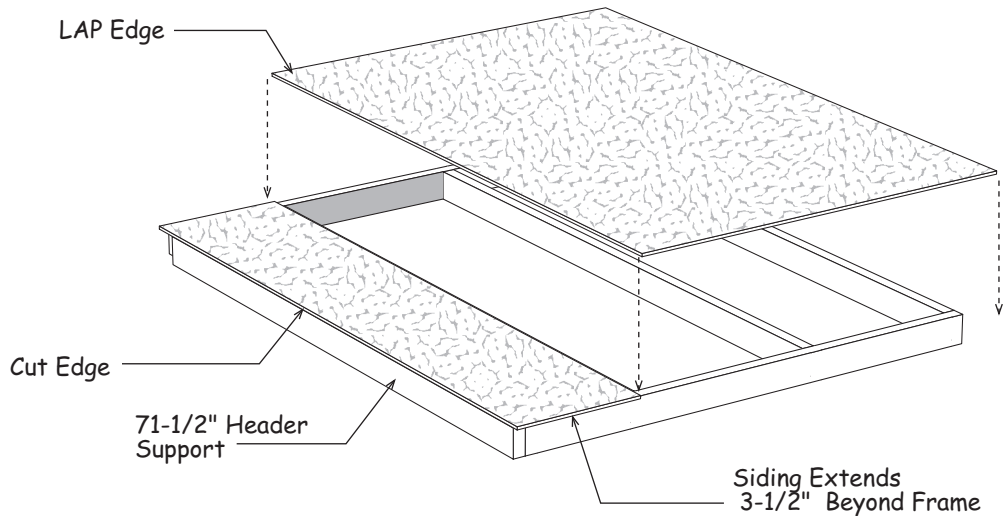

 **Skip to Step 10.**

Step 9 Assemble Sidewalls - Double Doors Offset

1. Locate 34-3/4" long board. Cut (2) two boards to a length of 11".
2. Assemble a 11" wall frame with the plates cut above and (2) two wall studs. Use 10d sinkers.
3. Assemble a wall frame using (4) four 72" wall studs and (2) tw48" long 2x4 wall plates.

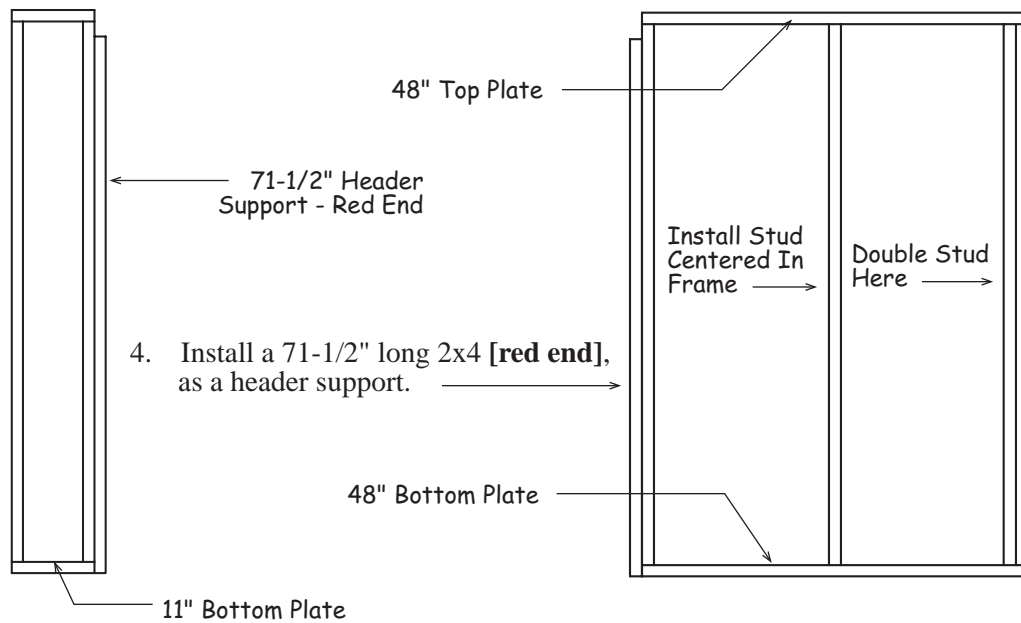

5. Assemble a wall frame using (4) four 72" wall studs and (2) two 58-1/2" long 2x4 wall plates. Use 10d sinkers.

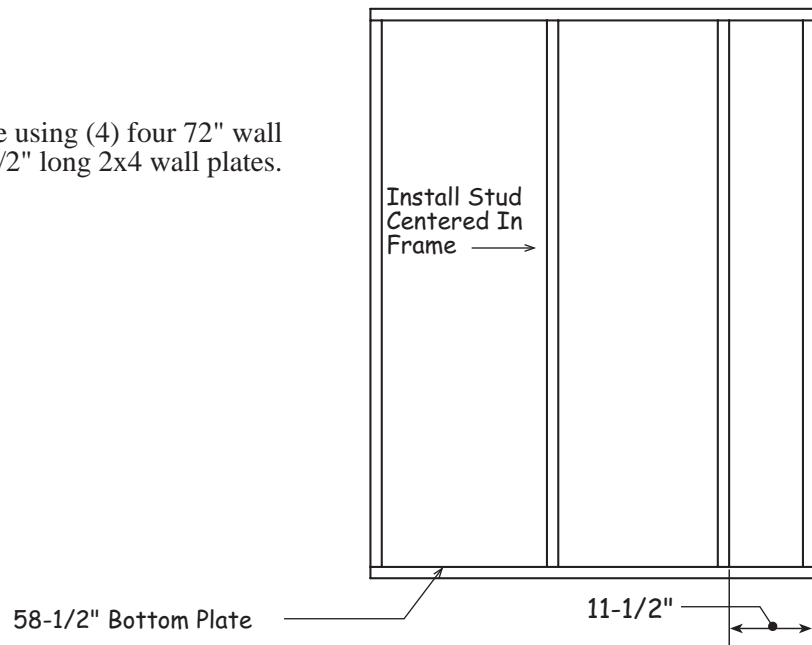

Step 9 Assemble Sidewalls - Double Doors (continued)

1. Install a 16" siding panel with the tongue edge flush with the side of the header support.

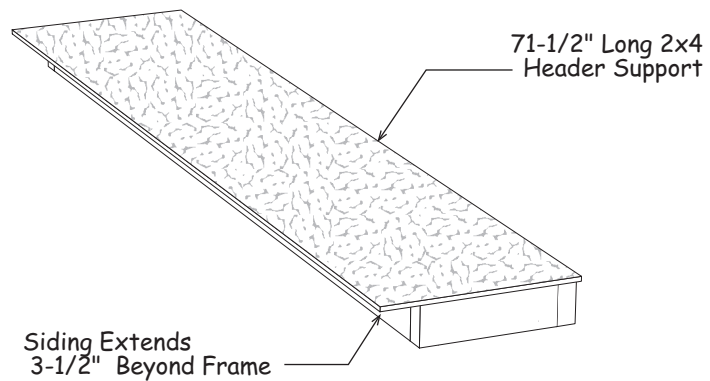

- ✱
2. Nail the 48" wide wall frame to the larger 58-1/2" wall frame. Use 10d sinkers.
 3. Install (2) two 48" wide siding panels. Install the first panel with the 'LAP' edge flush with the 71-1/2" long header support. If you are installing an optional window, you can cut out the window opening now or later.
 4. Install a 16" wide siding panel. The siding will extend 3-1/2" beyond the frame.

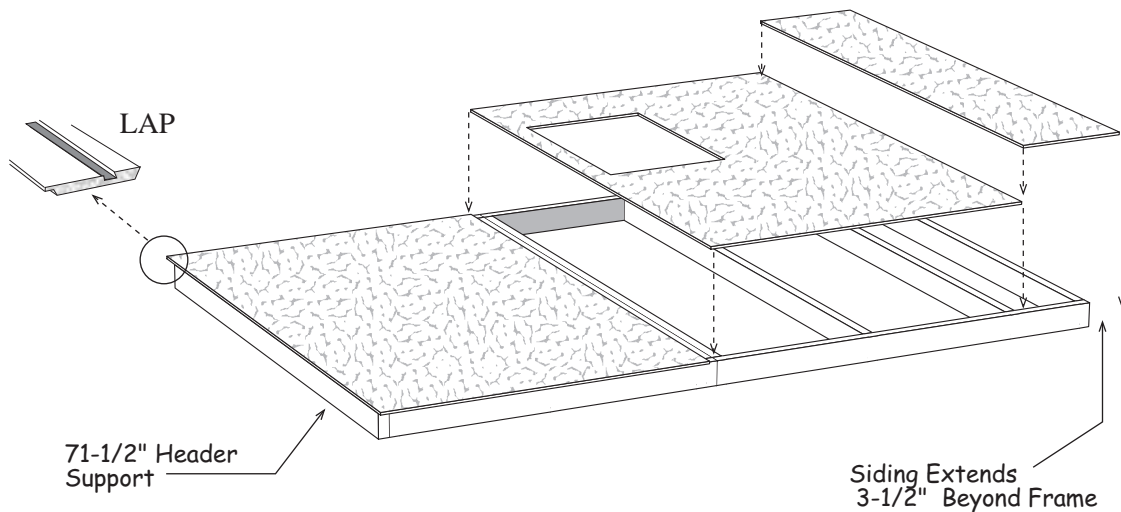

Step 10 Set Walls Panels



*If you want the double doors on the opposite sidewall, see detail on Step 10A.
For offset double doors refer to Step 10B.*

1. Secure wall panels together at the corners. Use (4) four 10d coated nails per corner. Nail wall panels to the floor. Nail through the bottom plate. Space 10d sinkers 24" apart.
2. Install the 67-1/2" door header between the sidewall panels. Nail through the wall stud into the ends of the header. Toenail into the top wall plates. Door trim will hide where the siding panels butt together.
3. Install 2x4-6' boards at both sides of the door openings to hold the walls straight.

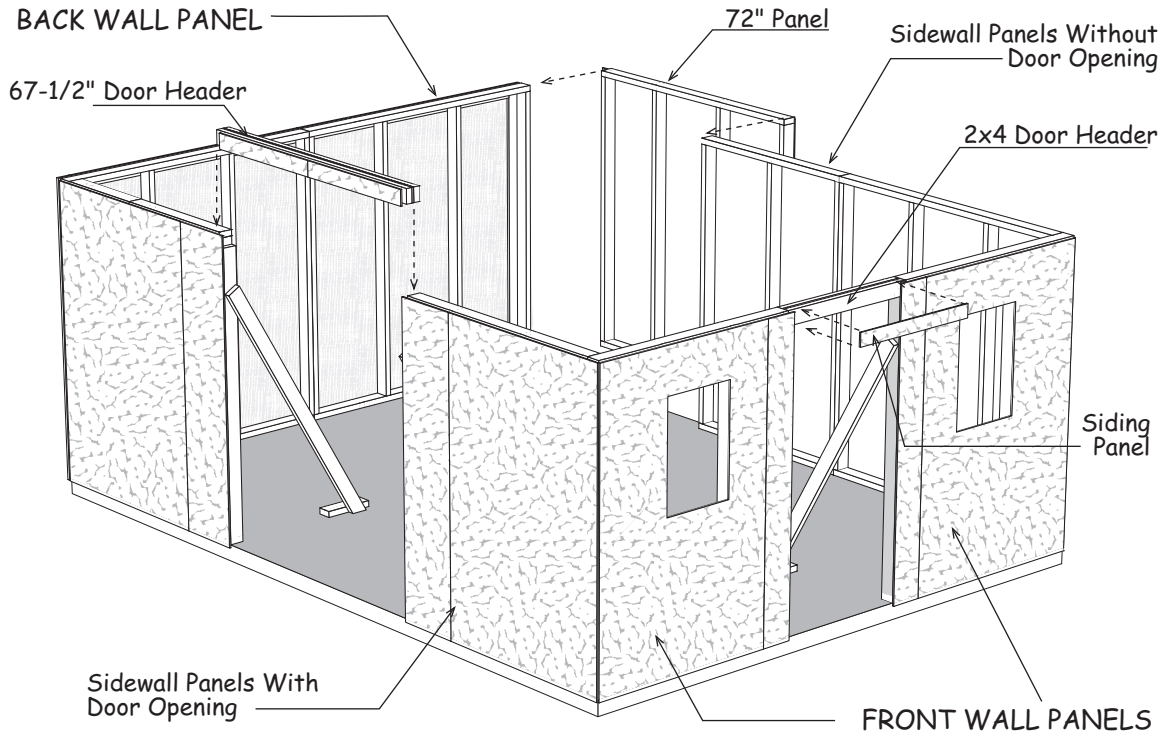

4. Install the door header, *assemble above*, between the front wall panels. Nail through the wall stud into the ends of the header. Toenail into the top wall plates. Door trim will hide where the siding panels butt together.
5. Install a siding panel over the door header. The siding will extend 3/4" below the door header.

Step 10A Set Walls Panels (continued)

1. Secure wall panels together at the corners. Use (4) four 10d coated nails per corner. Nail wall panels to the floor. Nail through the bottom plate. Space 10d sinkers 24" apart.
2. Install the 67-1/2" door header between the sidewall panels. Nail through the wall stud into the ends of the header. Toenail into the top wall plates. Door trim will hide where the siding panels butt together.
3. Install 2x4-6' boards at both sides of the door openings to hold the walls straight.

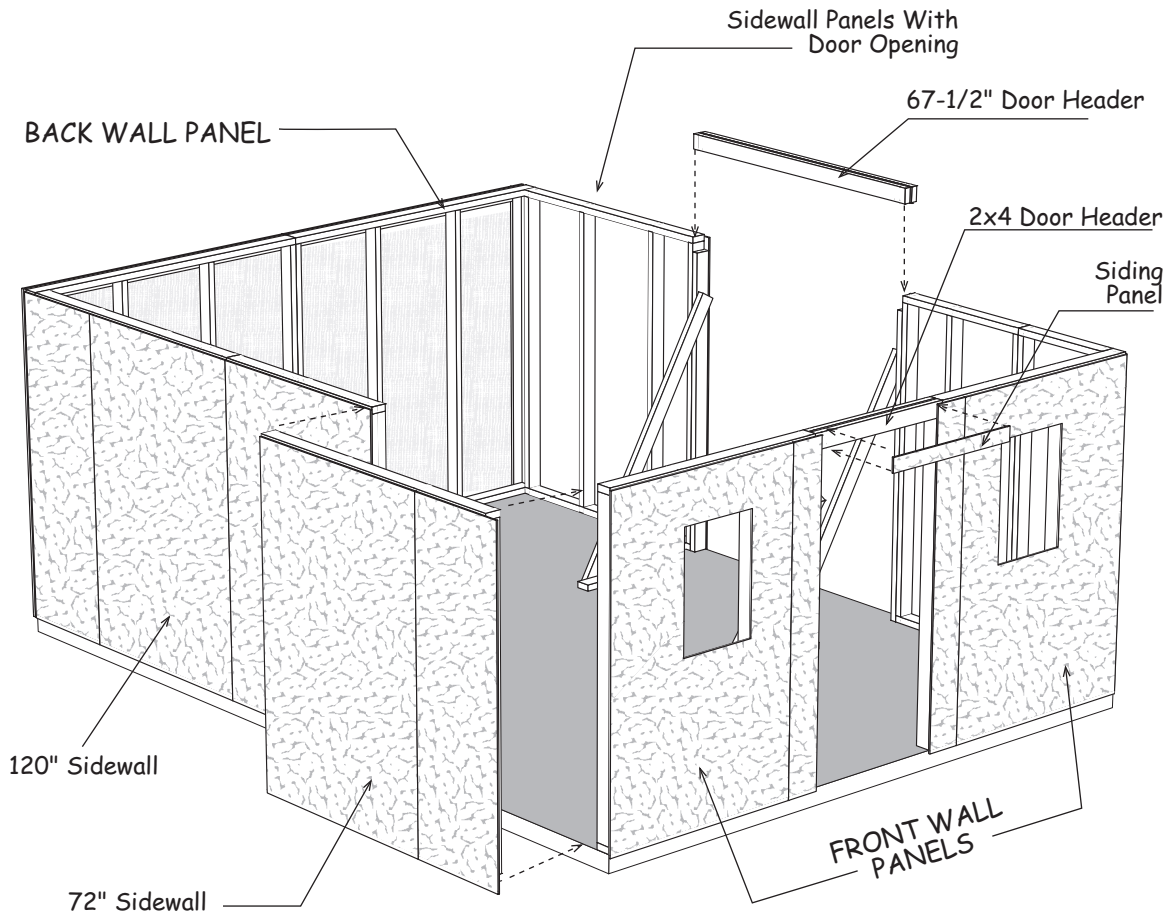

4. Install the door header, *assemble above*, between the front wall panels. Nail through the wall stud into the ends of the header. Toenail into the top wall plates. Door trim will hide where the siding panels butt together.
5. Install a siding panel over the door header. The siding will extend 3/4" below the door header.

Step 10B Set Walls Panels (continued)

1. Secure wall panels together at the corners. Use (4) four 10d coated nails per corner. Nail wall panels to the floor. Nail through the bottom plate. Space 10d sinkers 24" apart.
2. Install the 67-1/2" door header between the sidewall panels. Nail through the wall stud into the ends of the header. Toenail into the top wall plates. Door trim will hide where the siding panels butt together.
3. Install a 2x4-6' board at the side of the large door opening to hold the wall straight.

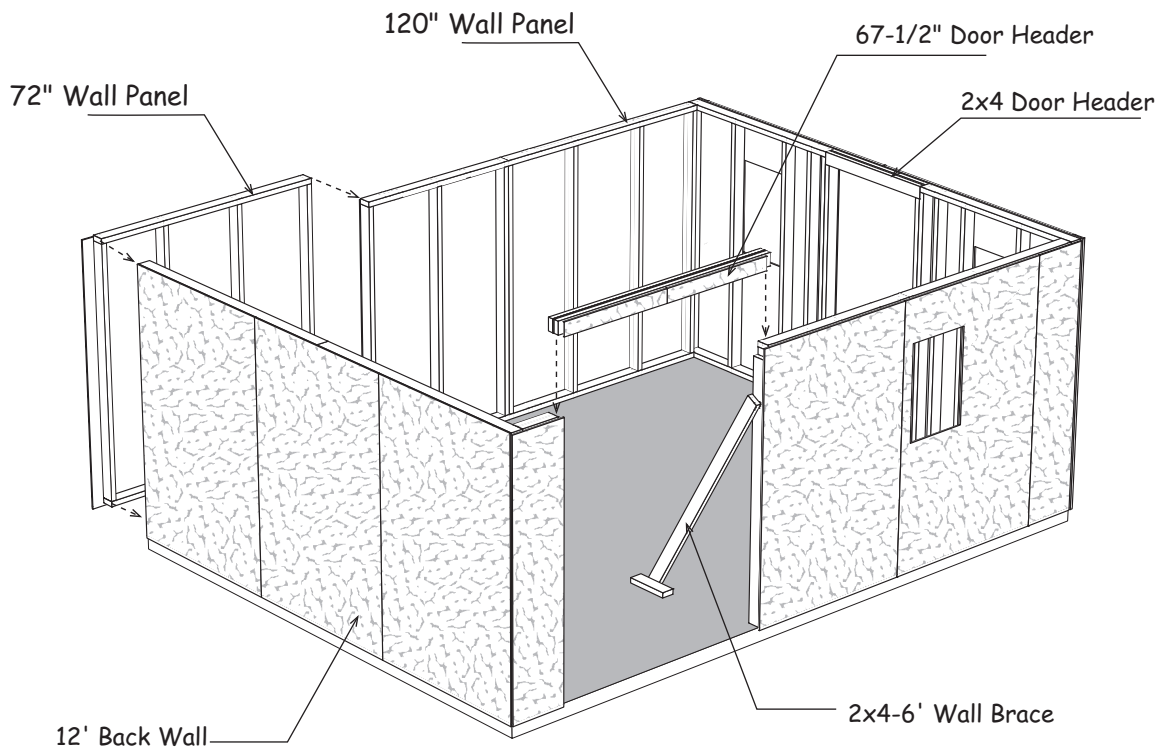

4. Install the door header, *assemble in Step 7*, between the front wall panels. Nail through the wall stud into the ends of the header. Toenail into the top wall plates. Door trim will hide where the siding panels butt together.
5. Install a siding panel over the door header. The siding will extend 3/4" below the door header.

Step 11 Install Trim on Front & Back Wall Panels

1. Install 1x4-75 3/4" corner trim boards to the back wall; see **Step 10**. Install trim flush with the 2x4 top plate and flush with the siding on the sidewalls. Use 8d galvanized box nails, spaced 12" apart.
2. Cut 1x4-6' trim boards and install between the corner trim boards.

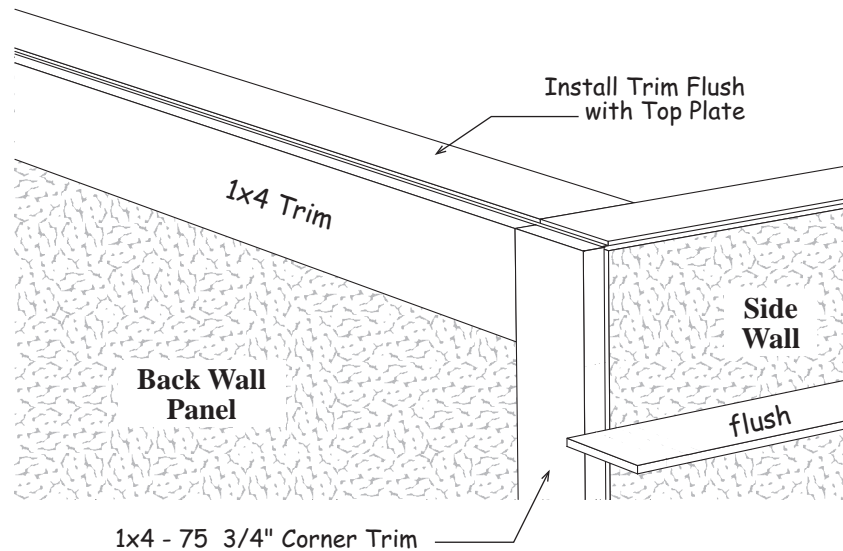

3. Install trim on the front wall of the building.

Step 12 Install Rear Gable

1. Install a gable on the rear wall. The gable siding will extend over the 1x4 trim on the lower wall. **NOT behind the trim!**
Secure gable to wall by nailing through the gable plate with 10d sinkers. Nail siding along the 1x4 trim board with 8d galv. nails.

2. Install gable on the front wall.

Important: Bottom edge of siding extends over 1x4 trim. Paint this edge.

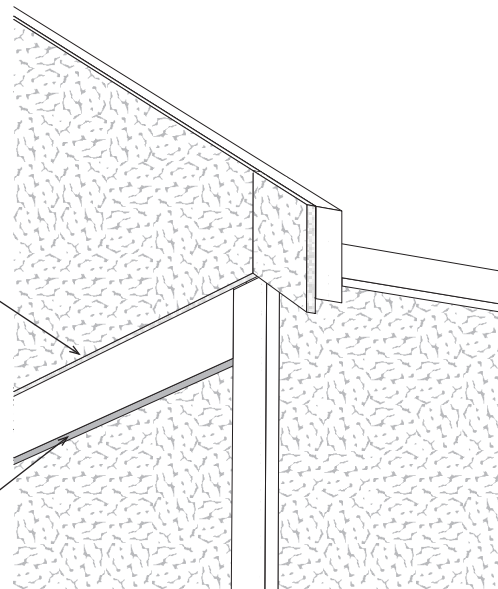

Step 13 Install 2x4 Tie Plates & Door Trim

1. Install a 4' long 2x4 and (2) two 2x4-6' boards as tie plates across the sidewall with the double doors. Use 10d sinkers.
2. Install plates on the opposite sidewall.

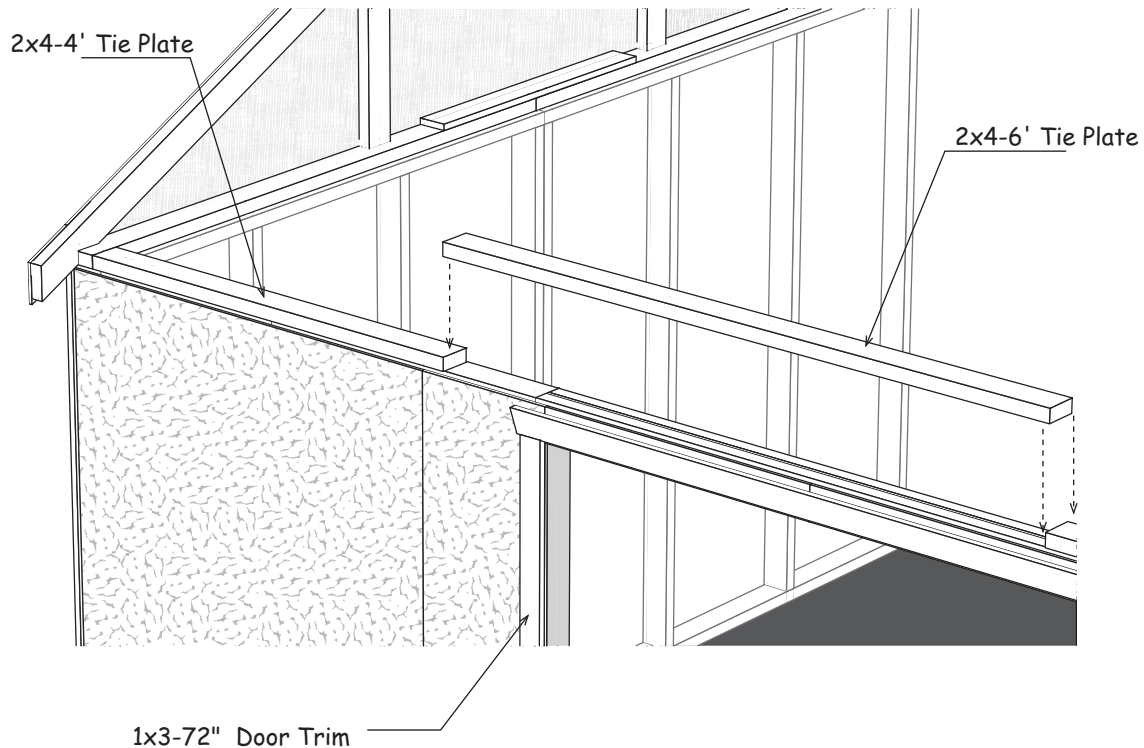

3. Install (2) two 1x3x72" boards along each side of the door opening, flush with the bottom edge of the siding. Tack these boards with a couple nails; you may want to move the trim later when you install the doors. Use 8d galv. nails.
4. Install a 1x3x71-3/4" board, that has angle cuts on both ends, across the top of the side trim.

Step 14 Layout Roof Trusses

1. Layout the truss spacing from the rear of the building. Measure from the backside of the 2x4 gable frame when marking the location of the first truss. **Important:** When marking the opposite wall, place the 'X' mark on the same side of the line so your trusses are parallel when they are installed.
2. Install metal hangers to the tie plate with 1-1/2" hanger nails. The opening should line up with the 'X' mark, the bottom of the opening, flush with the 2x4 tie plate. **Detail 'D'**.

Detail 'D'

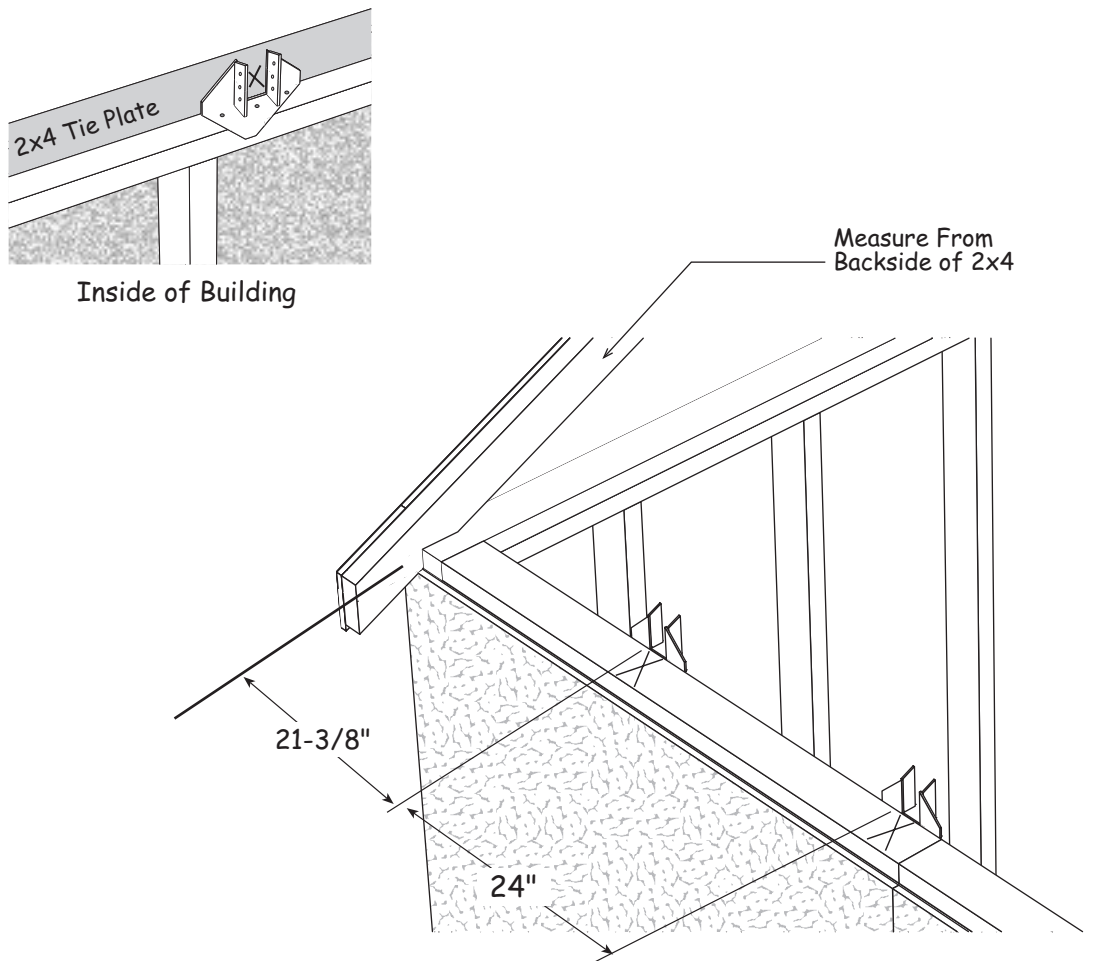

Step 15 Set Roof Trusses

Set roof trusses. Secure trusses to metal hangers with 1-1/2" hanger nails.

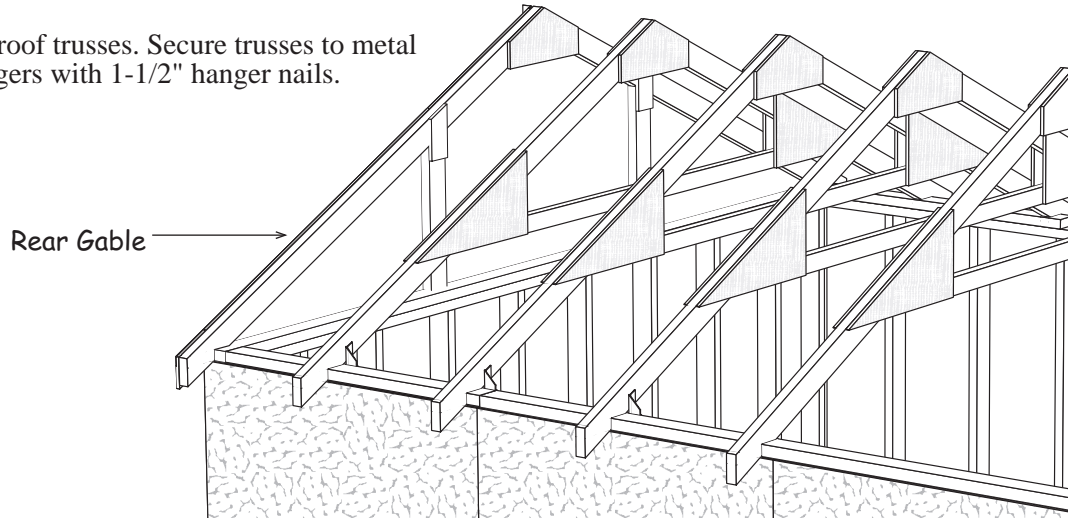

Step 16 Install Eave Soffit & Corner Trim

1. Locate a 5" wide x 24" siding panel that has a 'tongue' edge. Install this panel under the truss overhang at the rear of the building. Install the siding/soffit panel with the beveled edge flush with the end of the trusses and the cut edge against the gable siding. Use 6d galv. nails.
2. Install (4) four more full length siding panel under the trusses. Cut the last panel to fit.
3. Install soffit panels on the opposite side. Start with a 24" long panel that has a 'LAP' edge.

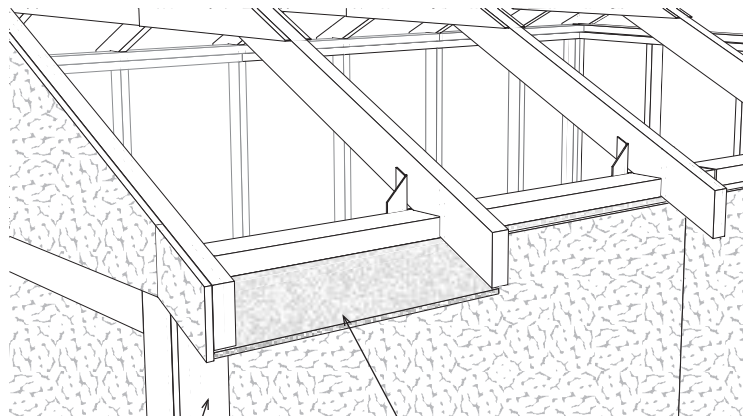

4. Cut 75-3/4" long 1x4 trim boards to length and install at the corners.

Soffit
Beveled Edge

Step 17 Install Roof Sheathing

1. Starting at the rear of the building, install 4'x6' OSB roof panels and 1x6-6' white pine fascia boards on each side. Install the roof sheathing and the 1x6 fascia boards flush with the face of the siding on the back gable. Install the fascia so the bottom edge of the roof sheathing will rest on the 1x6. See detail below. Use 8d galv. nails.

Make sure the trusses are plumb and the roof sheathing meets the center of the truss. Use 7d sinkers spaced 12" apart. The upper roof sheathing will be about 1" below the ridge to allow for ventilation.

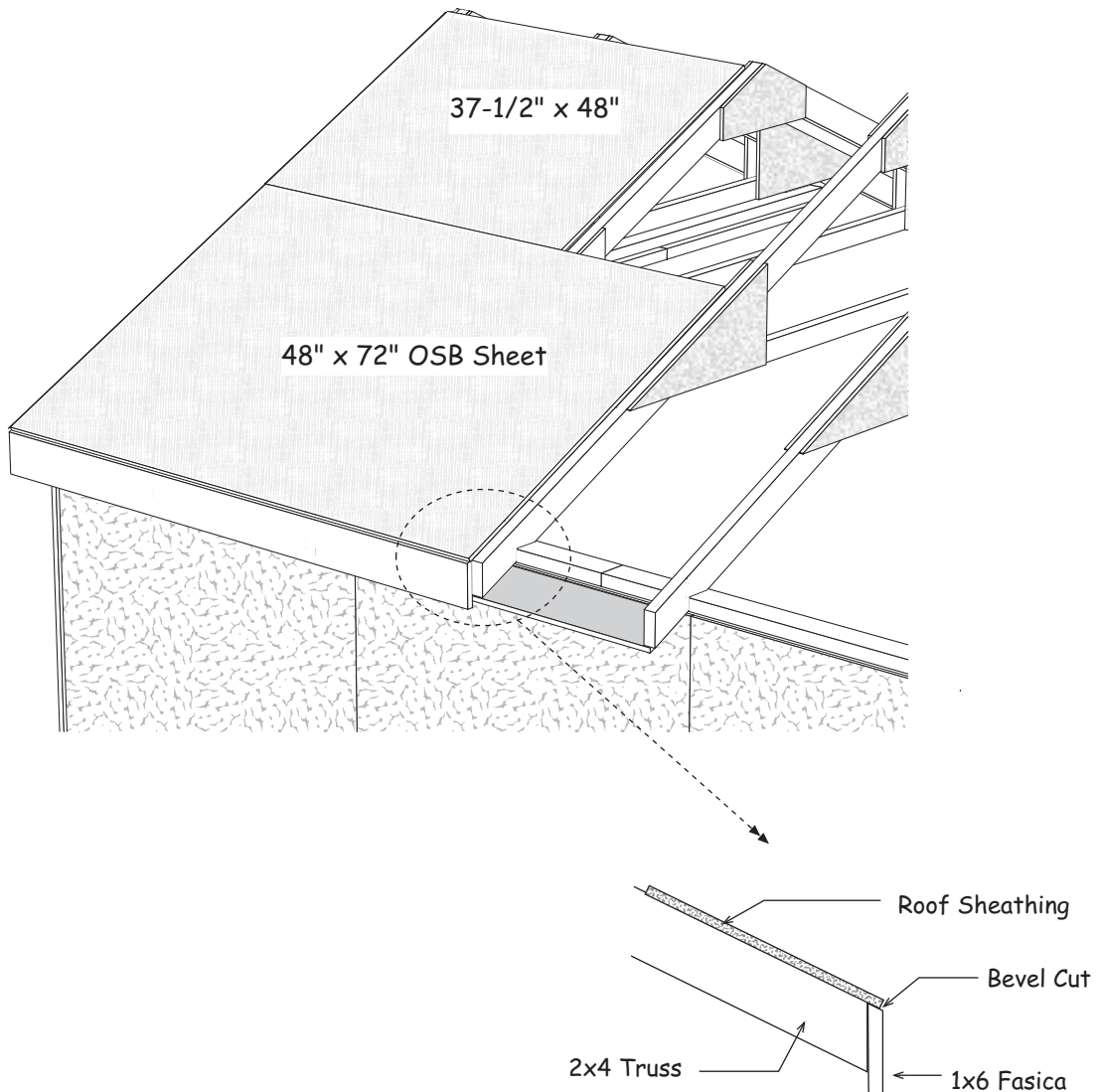

Step 17 Install Roof Sheathing (continued)

1. Install roof sheathing at the front of the building. The roof sheathing will extend past the front gable. Make sure the gable is plumb and the roof sheathing is overhanging the same distance beyond the front gable.
2. Install a 4' long 1x6 trim board in the center of the building. Cut a 1x6-7' board flush with the roof sheathing and install at the front of the building.

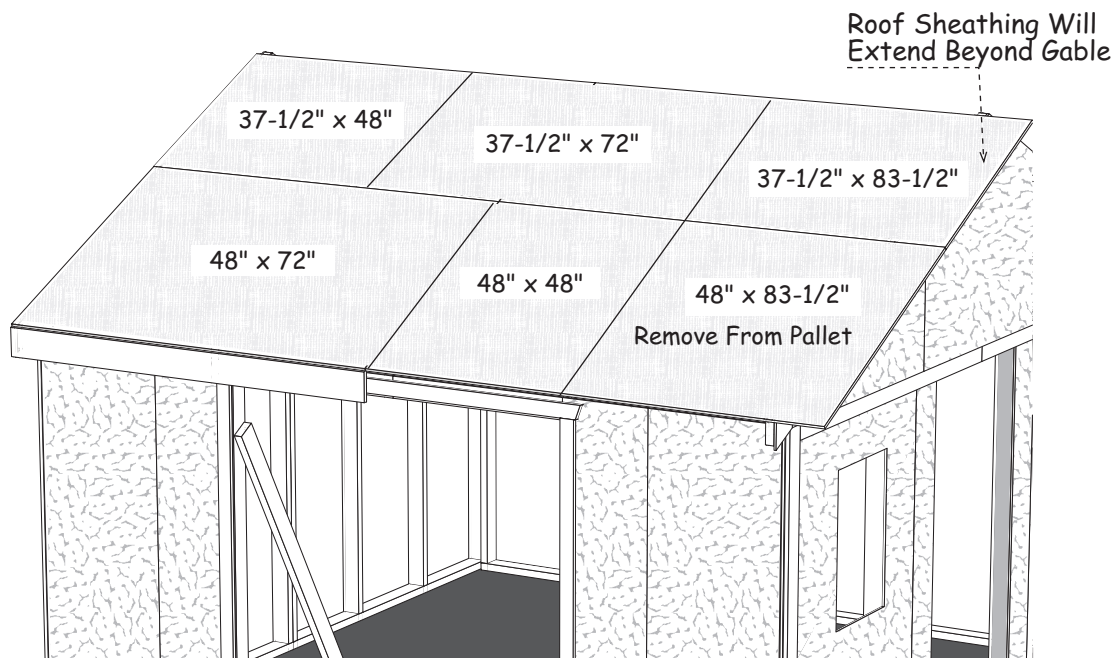

Step 18 Install Front Gable Soffit and Door Trim

1. Install 86-1/4" long 2x4s under the roof sheathing against the front gable.
2. Install 86" long 2x4s under the front edge of the roof sheathing. Hold the 2x4s against the roof sheathing and screw through the sheathing into the 2x4 boards. Use 1-5/8" long screws.
3. Install 8-1/2" wide siding under the gable overhang as the soffit. Use 6d galvanized nails.
4. Install (2) two 87" long 1x6 trim boards over the 2x4 boards, flush with the top of the roof sheathing. Use 8d galvanized box nails.
5. Install 1x6 trim on the back gable.

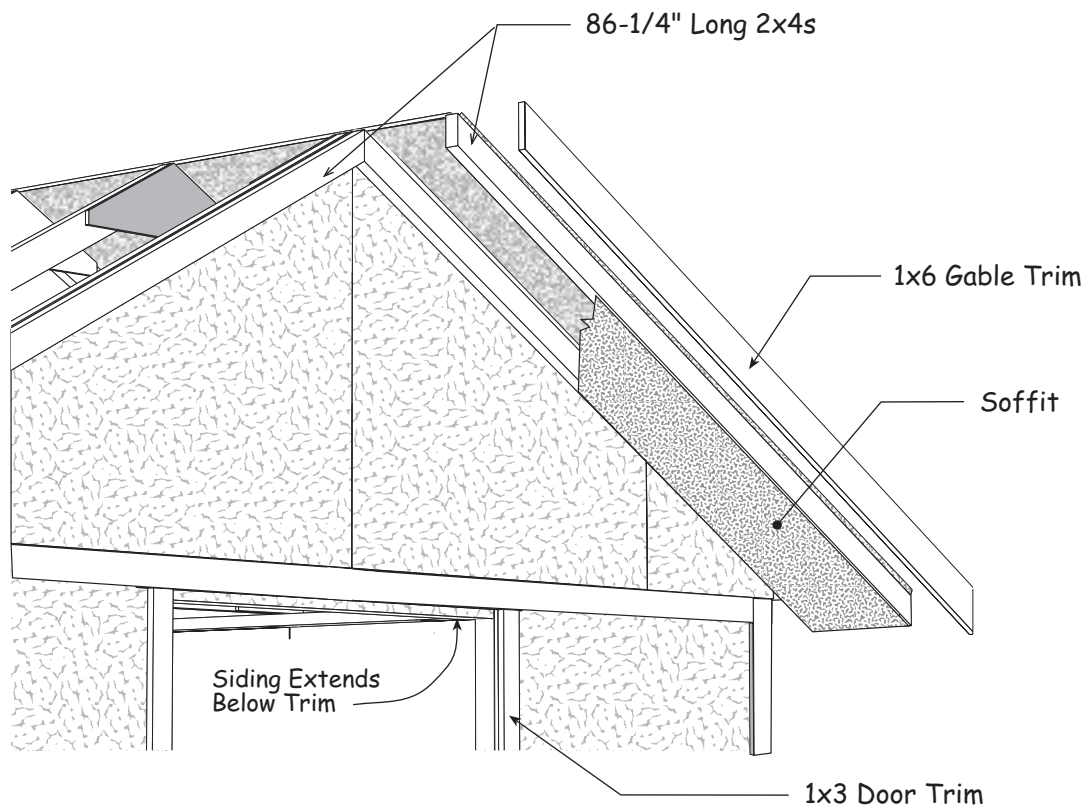

5. Locate (2) two 1x3-72" long trim boards. Tack these boards, *with a couple nails*, to each side of the door opening. You may want to move the trim later when you install the door.

Step 19 Install Doors & Hardware

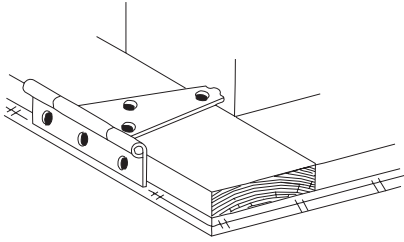

1. Lay the left door with the trim facing up. The siding on the left door extends past the door trim. See detail below.
2. Install 5" hinges to the left side of the door frame. To position the hinge properly, hold the rectangular plate against the frame. Use 1-3/4" black screws.
3. Install hinges to the right side of the other door.

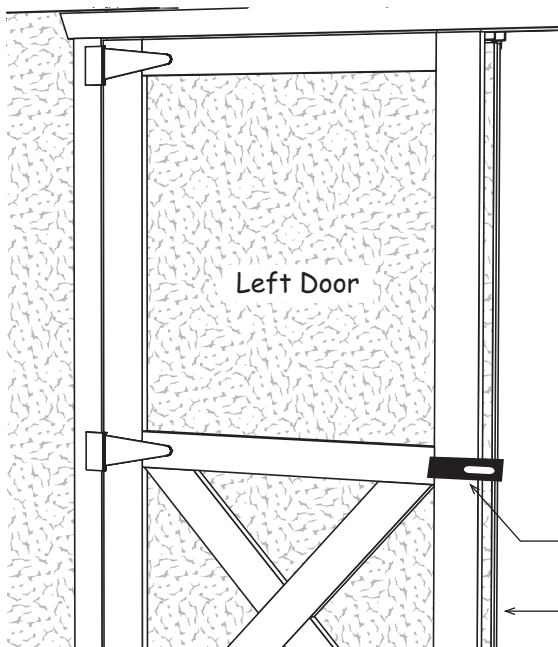

4. Before you fasten the hinges to the door trim, temporarily prop the doors in the opening. Leave a space at the top of the doors and between the doors and the side trim to allow room for the doors to expand when they absorb moisture.

If your door opening is out of square, the space around the doors will not be even. You can remove and reposition the side trim to make allowances for this. The side trim does not have to be flush with the frame of the door opening. You can move the trim in or out to make the door spacing equal.

5. Install hinges to trim with 2" screws.

Barrel Bolt on the back of left door

6. Install a barrel bolt on the lower back of the door to secure this door in place when closed. You will need to drill a hole for the round shaft to drop into.
7. Install another barrel bolt at the top of the door.

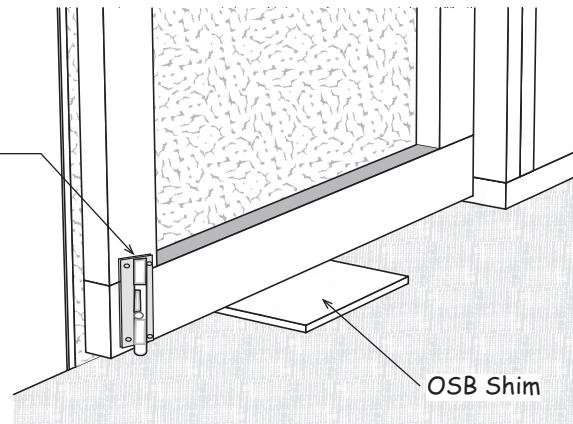

OSB Shim

Install Roofing — Not Supplied in Kit

Install metal roof edging on perimeter of the roof area. If you are not installing shingles at this time, you can purchase felt paper to protect the sheathing. Install the felt paper before you install the metal roof edge.

Install shingles according to the instructions on the wrapper. Additional information and tutorials can be found on various online sources.

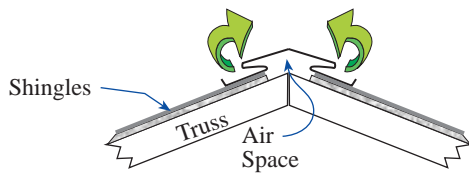
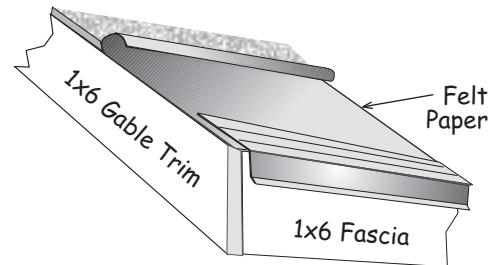

Optional ridge vent provides ideal ventilation.

Building Tip: Install ridge vent in lieu of shingle caps. Ridge vent provides ideal ventilation, preventing heat and moisture build-up from damaging your building or its contents.

Material Packaged In Component Kit

7	Collar Ties	2x4	90"	4	1 lb. box	10d	Sinkers
22	Truss Rafters	2x4	86-1/4"	4	1 lb. box	8d	Galv.
54	Wall Studs	2x4	72"	3	1 lb. box	7d	Sinkers
4	Door Jacks	2x4	71-1/2"	1	1 lb. box	6d	Galv.
4	Wall Plates	2x4	68-1/2"	4	1 lb. box	6d	Common
2	Wall Plates	2x4	58-1/2"	1	1 lb. box	1-1/2"	Hanger Nails
6	Wall Plates	2x4	48"	9	ea.	5"	Door Hinges
2	Door Header	2x4	35-1/2"	2	ea.	4.5"	Door Latch
2	Wall Plates	2x4	34-3/4"	2	ea.	6"	Barrel Bolts
4	Gable Studs	2x4	23-1/2"	72	ea.	2"	Hinge Screws
14	Truss Gussets	7/16"	8" x 20"	6	ea.	1x4	Metal Plates
28	Truss Gussets	7/16"	12" x 24"	14	ea.	2x4	Metal Truss Hangers
2	Soffit Boards	3/8"	5" x 24"	2	ea.		Bottle Glue
8	Soffit Boards	3/8"	5" x 48"	1	ea.		Header Filler 3-1/2" x 35-1/2"
12	Siding Panels		48" x 75-1/4"	2	ea.		Plywood Gussets 3-1/2" x 32"
2	Siding Panels		16" x 75-1/4"	8	ea.		2x4 Truss Jig Blocks 10"
2	Siding Panels		8" x 75-1/4"	4	ea.		1x6 Gable Trim 87"
2	Gable Siding Panels		48" x 40"	2	ea.		1x6 Fascia Trim 84"
4	Gable Siding Panels		48" x 28"	2	ea.		1x6 Fascia Trim 72"
1	Door Header Siding		3-3/4" x 32-1/2"	2	ea.		1x6 Fascia Trim 48"
2	Roof Sheathing		48" x 83-1/2"	8	ea.		1x4 Corner Trim 75-3/4"
2	Roof Sheathing		37-1/2" x 83-1/2"	4	ea.		1x4 Wall Trim 72"
2	Roof Sheathing		48" x 72"	4	ea.		1x3 Door Trim-sides 72"
2	Roof Sheathing		37-1/2" x 72"	1	ea.		1x3 Door Trim-top 71-3/4"
2	Roof Sheathing		48" x 48"	3	ea.		Pre-built Door 32' x 71-3/4"
2	Roof Sheathing		37-1/2" x 48"	1	ea.		Pre-built Door Header 67-1/2"
4	Front Soffit Panels		8-1/2" x 48"				

Building Size		Optional Shingles
12x12	12x16	
8 bdl.	10 bdl.	Roof Shingles
7 pcs.	8 pcs.	Roof 'drip' Edge 10'