



# Best Barns USA Assembly Book

Revised May 5, 2019



***the Aspen II***

**12' x 8'**

---

**Manufactured by Reynolds Building Systems, Inc.**

205 Arlington Drive, Greenville, PA 16125

This manual is copyrighted. Under the copyright laws, this manual may not be copied, in whole or in part, without consent from Reynolds Building Systems, Inc. © Copyright 2016

## IMPORTANT INFORMATION ABOUT YOUR SHED KIT

Thank you for your purchase. I want you to be completely satisfied with your building. The 2x4s we use in our kit are the best grade available, importing most from Europe. If you are dissatisfied with any lumber, we will replace it.

Read the instructions before starting the assembly of the building. If you have any questions about assembling the kit, call 800-245-1577. Business hours (8:00-5:00 ET) Monday thru Friday. After business hours call 724-866-HELP (4357) or email to help@barnkits.com.

The material that is included in our kit is listed on the back page. The optional floor package, if purchased, will be supplied by a local lumber supplier.

You will need to purchase the finish roof covering (shingles or metal panels) locally. Refer to back page for information on suggested material.. The siding is primed. You will need to apply a finish coat using latex acrylic paint.

Some of the framing lumber was used in the shipping pallet. Unpack the material from the pallets, then unscrew the top 2x4s. The bit for the screws is packed in the hardware bag. The 2x4s and the OSB boards will be used for wall bracing and optional shelving.

Most buildings are installed on a wood floor and the siding was designed to extend over the wood flooring. If the foundation is a concrete floor cut the siding flush with the bottom of the wall plate to prevent the concrete from contacting the siding.

Stacking the boards, according to size, will make them easier to find when needed. **Do Not** discard any material until your building is complete.

Before building, obtain a building permit and check all pertinent building code regulations.

*The siding is made in 4x8 sheets with grooves cut into the face, the long edge is beveled so that the siding overlays where they butt.*

*To identify which edge we want you to use, we will refer to the edge as either the 'LAP' Edge or the Tongue Edge. Nail siding with 8d galv. nails, spaced 12" apart.*

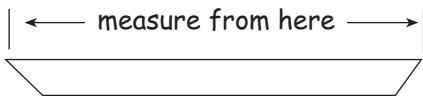
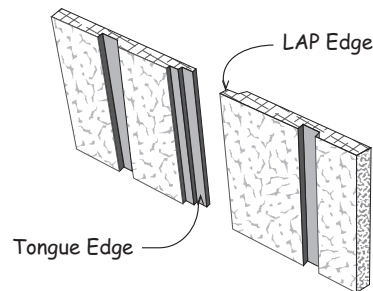

When measurements are given for a board length, it is from the longest side.

## Tool List

- |  |  |
|--|--|
| <input type="checkbox"/> Hammer & Phillips Screwdriver | <input type="checkbox"/> Power Drill/Screwdriver |
| <input type="checkbox"/> Framing Square & Level        | <input type="checkbox"/> Measuring Tape          |
| <input type="checkbox"/> Hand Saw                      | <input type="checkbox"/> 2-8' Step Ladders       |

**Always wear safety glasses when cutting or nailing!**

## Construction Details for Optional Floor System

Check local building codes in your area, the construction may have to change. For a concrete slab, install sill sealer as a moisture barrier between the concrete and the wall plates. Foam sill sealer can be purchased at home centers in rolls 3-1/2" or wider.

1. Treated lumber is not cut to exact length. Cut (2) two 2x4-12' boards to 12'-0".  
Layout for 16" on center joist spacing. 'X' marks where floor joist will be placed.

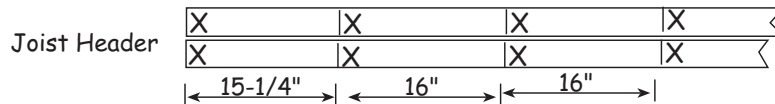

2. Cut 2x4-8' floor joists to a length of 7'-9". *Treated lumber may be thicker than 1-1/2". Take this into account when cutting the length of floor joists. Shorten joist measurements if necessary to obtain 8'-0" building width.*
3. Install the floor joists, *over the 'X' marks*, between the 12' long joist headers. Use 16d galv. deck nails.

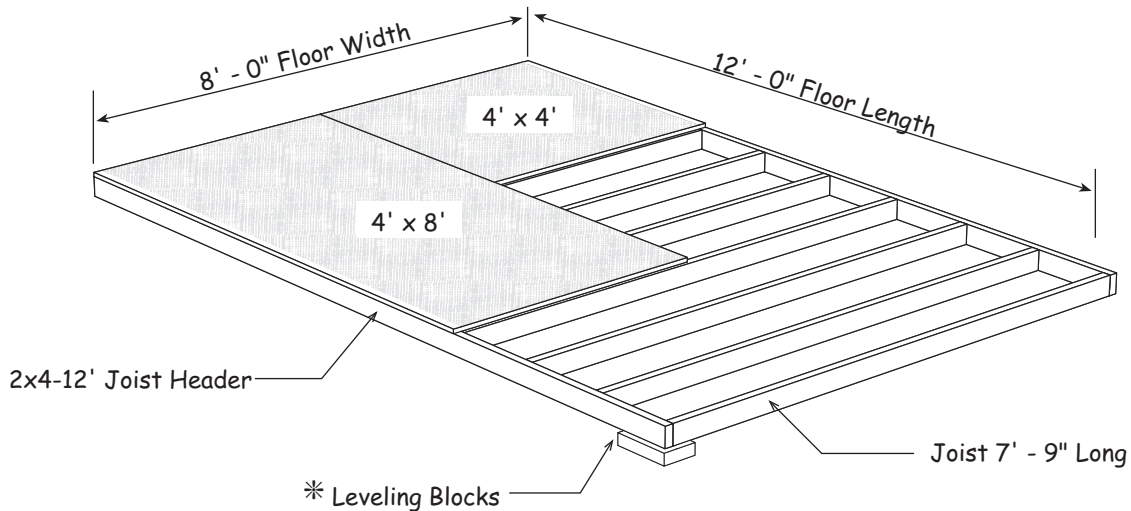

\* *If necessary use bricks, patio stones or similar material to level or provide additional support to the floor. If your ground has low areas consider adding gravel and or 4x4 treated timbers to rest the floor on. If you use 4x4 timbers you will need (3) three pieces 12' long.*

It is important that the floor be level and square. Before nailing the flooring, measure the floor diagonally (corner to corner). Then measure the opposite corners. These measurements will be the same if the floor is square (173").

Material Description	8' x 12' Floor	
2x4 Treated Headers	2 pcs.	12'
2x4 Treated Floor Joist	10 pcs.	8'
Flooring 5/8" 4x8	3 pcs.	4x8
8d Screw Floor Nails	1 lb.	8d
16d Galv. Box Nails	1 lb.	16d

## Step 1 Assemble End Wall Frames

1. Install (3) three 2x4-72" wall studs between (2) two 48" long 2x4s. Install the center stud in the middle of the wall frame.

Use (2) two 10d sinkers at each end of stud.

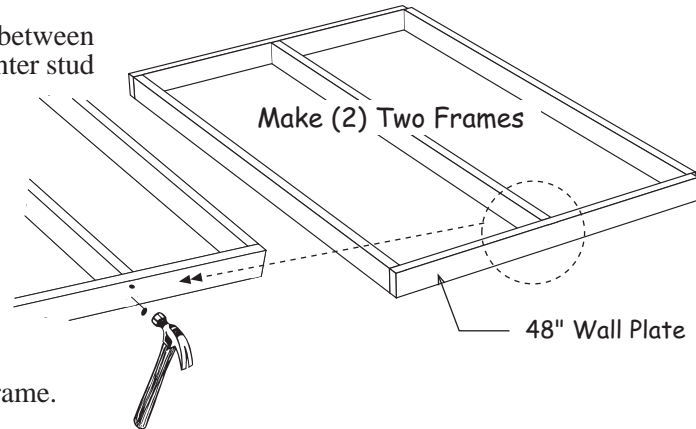

2. Repeat to make (1) one more 48" frame. Set aside.
3. Place (1) one of the 48" wall frames on floor positioned on the left. *Square frame by measuring diagonally (corner to corner)*. The measurements will be the same when square.
4. Locate the (2) two pre-built 48" wall frames. Position *the one without the center stud* against the 48" wall frame with the angle part of the frame on the right.

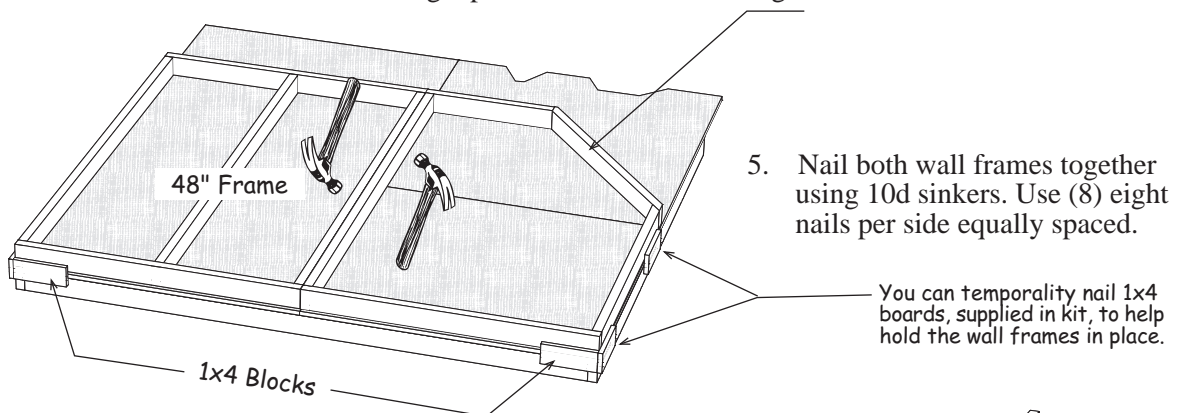

6. Install a 72" long 2x4 in the center of the wall frame. Refer to the other pre-built wall frame for proper position.

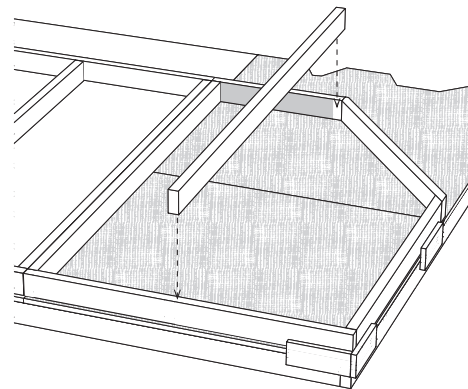

## Step 1 Assemble End Wall Frames Contined

7. Install the siding panel with the angle cut with the 'LAP edge' flush with the end of the wall with the siding extending  $\frac{3}{4}$ " below the bottom plate. The siding will extend  $\frac{1}{2}$ " above the wall frame angled frame and 1" above top plate. Use 8d galv. nails spaced 12" apart.
8. Install a full width x 76- $\frac{3}{4}$ " siding panel on the left. Siding will extend  $\frac{3}{4}$ " below bottom plate and extend 1" above the wall frame. Set wall aside.

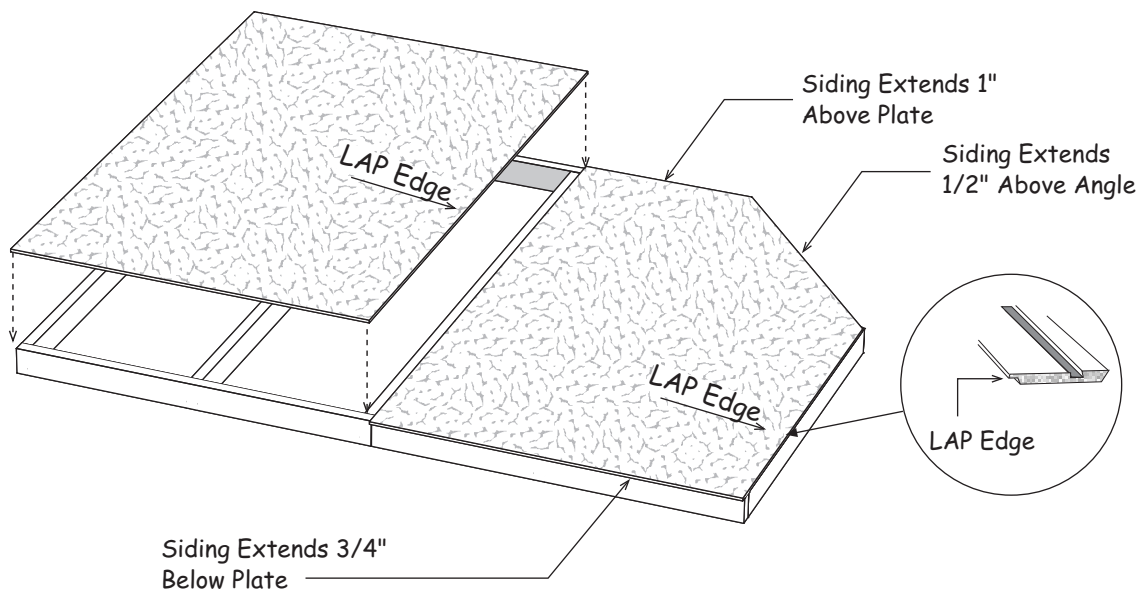

9. Position the other set of end wall frames on the floor. This time with the frame with the angle corner on the left as shown.
10. Working from left to right install (2) two more siding panels as done above. **DO NOT REMOVE WALL FRAME** from floor.

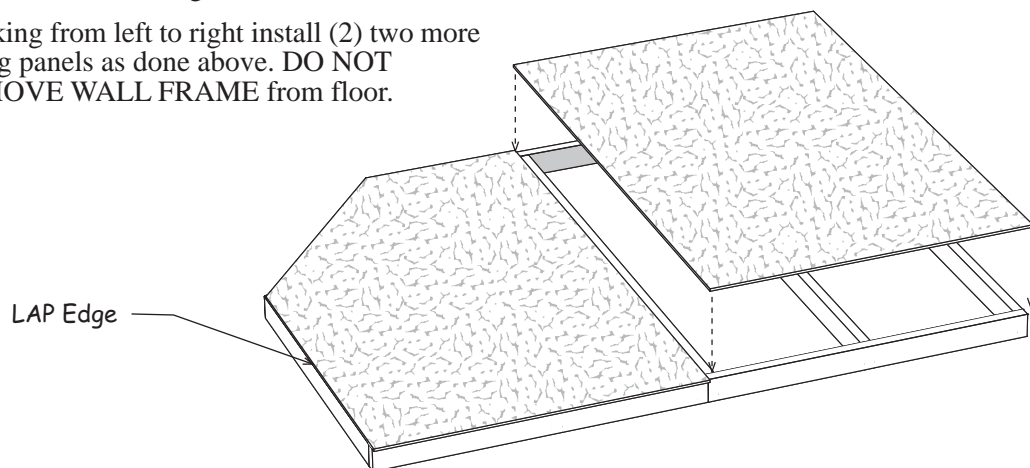

## Step 2 Assemble Roof Trusses

1. Position one of the pre-built gable frames against the top edge of the end wall panels. Temporarily nail 1x4 blocks to the floor along the edge of the gable frame and on the angle of wall. The gable frame is not attached to wall in this step.
2. Remove the wall panels and the gable frame. Do not remove the 1x4 blocks. They will be used in the next step to make sure the trusses are assembled identically.

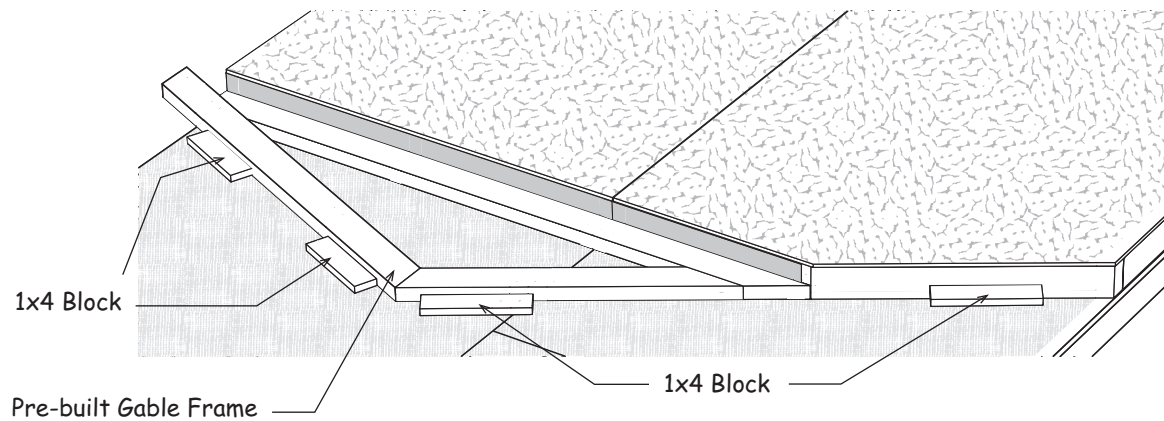

3. Position a 69-1/2" long 2x4 and a 47-1/8" long 2x4s on the floor against the 1x4 blocks and secure the 2x4s together with a wood gusset. Using (10) ten 6d common nails evenly spaced.

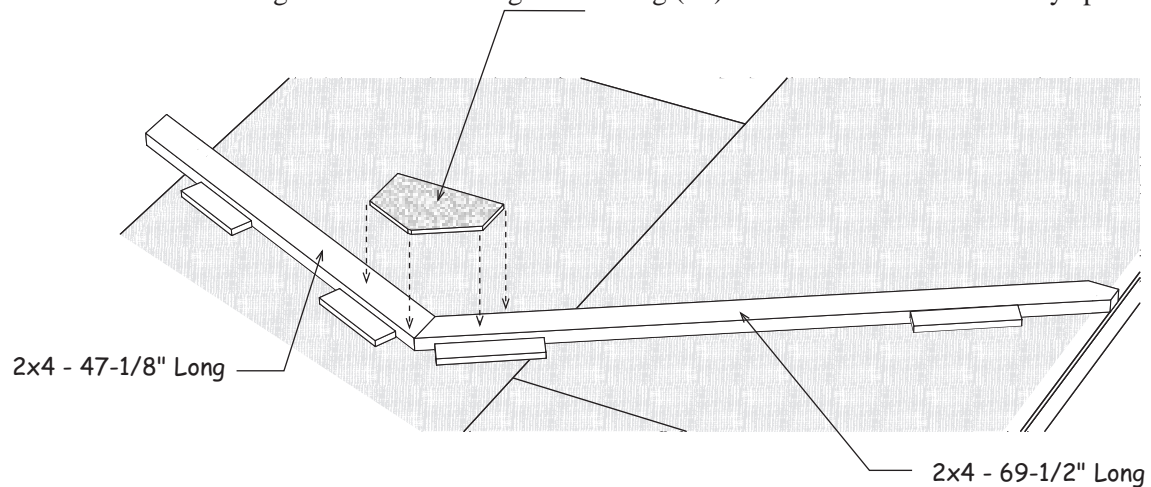

4. Turn truss over and apply wood gusset to the opposite side.
5. Assemble (4) four more trusses.

## Step 3 Assemble Front Wall Frames

1. Position (2) two 72" long 2x4 boards together and indicate where the wall studs will be located by drawing lines and placing 'X' marks as shown.

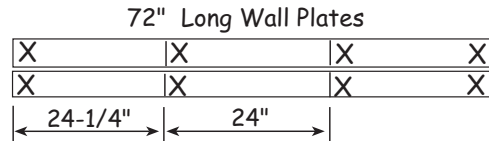

2. Install (4) four 2x4-72" wall studs between the 2x4s from above. Use 10d sinkers.
3. Install (2) two 72" wall studs between (2) two 13-1/2 long 2x4s .
4. Install a 72" long 2x4 at the end of each wall frame flush with bottom of bottom plate. These will support the door header installed later.

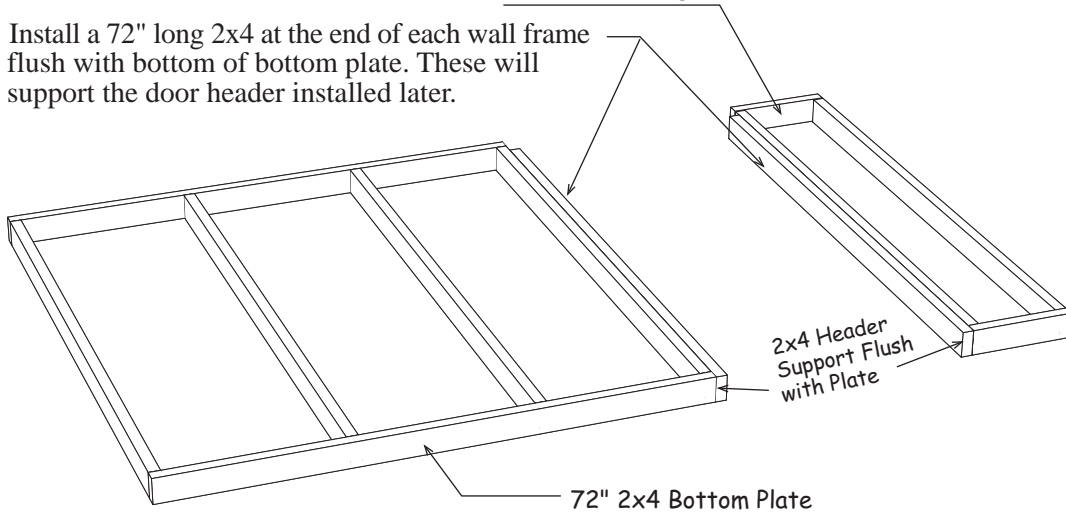

 *If you want to locate the door on the left turn the walls over before applying the siding.*

4. Install a 30" x 76-3/4" siding panel. The siding will extend 3-1/2" beyond the left end of the wall frame. The siding should extend 3/4" below the bottom plate and will extend 1" above the top plate. Install a full width x 76-3/4" siding panel on the right side of the wall panel. This panel will be flush with header support.

 *If you purchased optional windows you can cut the opening now or later. Refer to instructions in window box.*

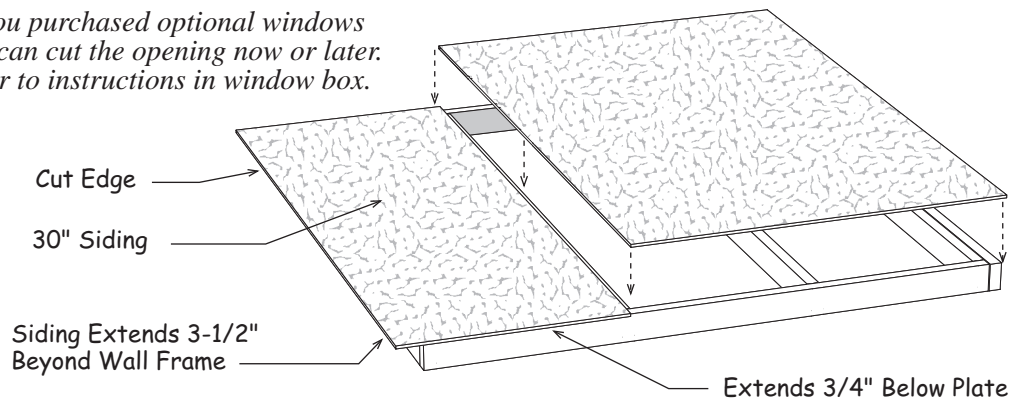

## Step 4 Assemble Back Wall

1. Position (4) four 68-1/2" long 2x4s together and indicate with 'X' marks, where the wall studs will be located. Mark the ends that will butt together with the letters 'A' and 'B'.

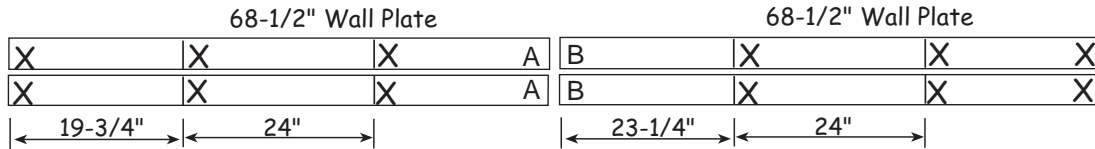

2. Install 52-7/8" long wall studs, between the wall plates, over the 'A', 'B' and 'X' marks. Use 10d sinkers. Nail wall frames together.
3. Disassemble the shipping pallet and remove (4) four 2x4. The screw bit is in the hardware bag.
4. Cut (1) one 77" long 2x4 into (2) two pieces 30" long. Install first piece flush with end of wall.
5. Install a 77" long 2x4 next. Finish with 2nd 30" long 2x4. *Square wall frame.*

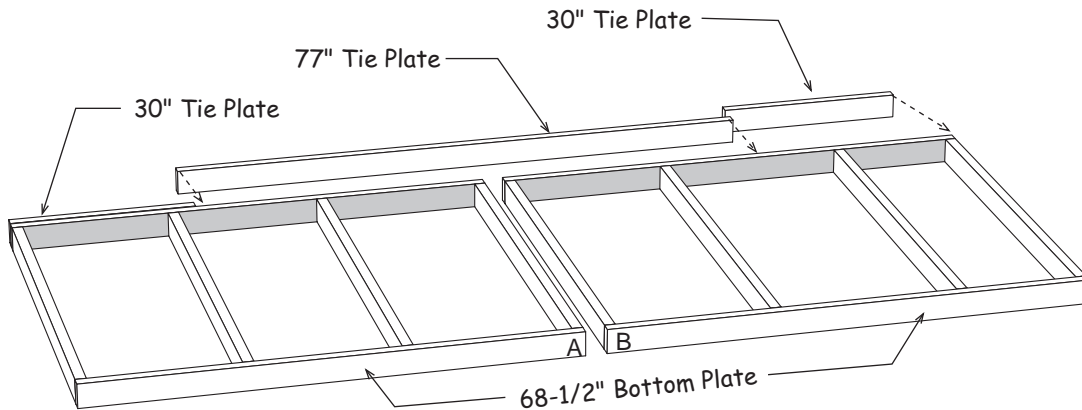

6. Install (3) three full width x 60" siding panels. The siding should extend 3-1/2" beyond the wall frame on left, 2" above top and 3/4" below bottom plate.

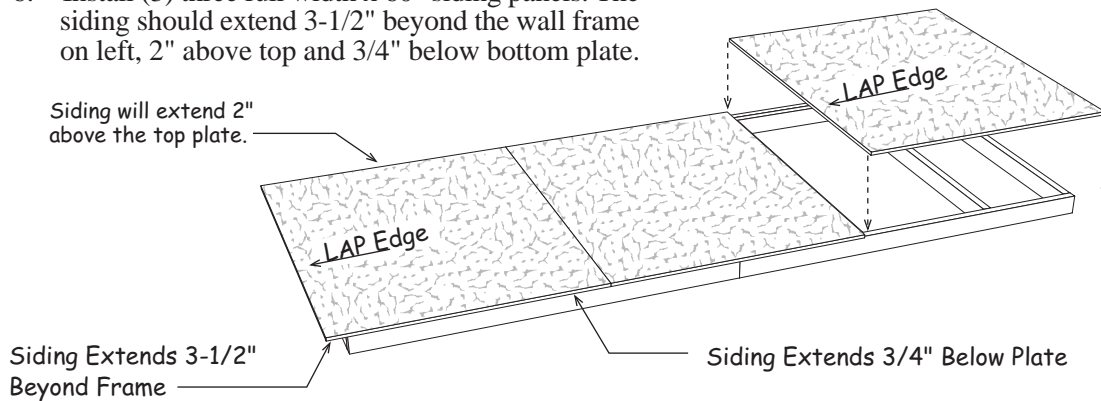



## Step 5 Set Walls

1. Set the back wall and end wall on floor. Secure walls at corner with 10d coated sinkers. Nail bottom plate to floor. Use leftover galv. nails from the wood floor assembly.
2. Set the larger front wall panel.

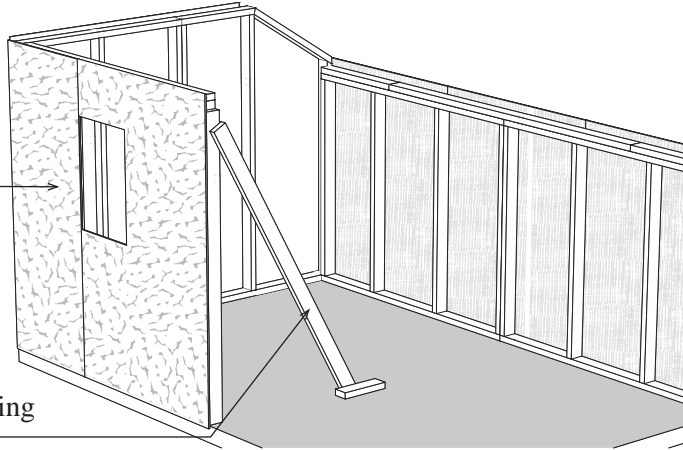

3. Use one of the 2x4s from the shipping pallet to brace the front wall.
4. Install the other end wall panel and the 13-1-2" wall frame. Brace wall frame with another 2x4 from the shipping pallet.
5. Insure walls are plum and door opening is square.
6. Install (2) two 51-1/2" long 2x4s. Nail 1st board into top of header supports using 10d sinkers. Then nail 2nd board to 1st.

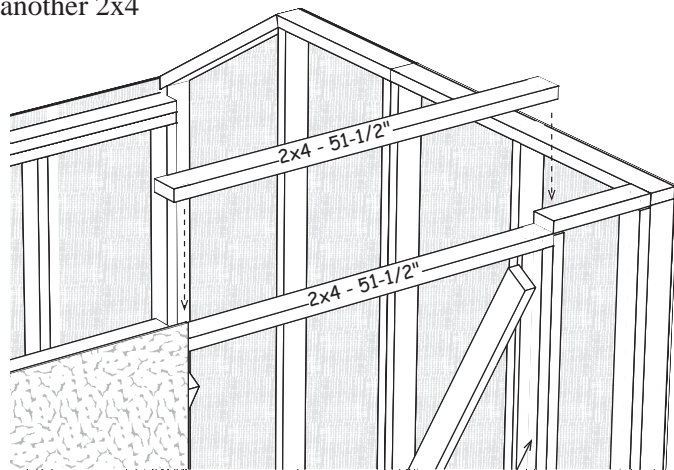

5-1/2" High Siding

2x4 Header Support

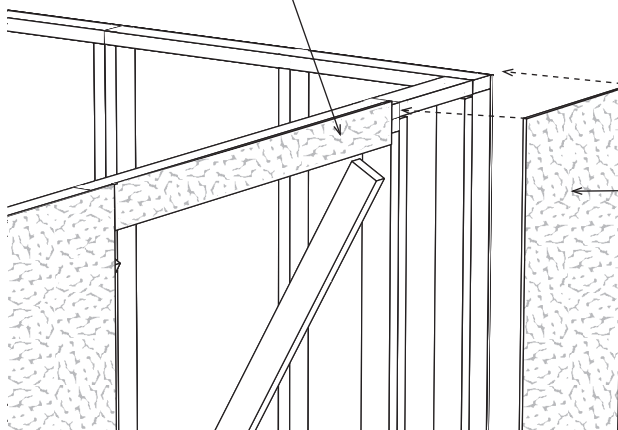

7. Install a full width x 4-3/4" siding panel over the door header. Install 1" above top of 2x4.
8. Install a 18" x 76-3/4" siding panel to finish.

## Step 6 Set Gables - Install 2X4 Tie Plates

1. Position a pre-built gable frame on the end wall flush with outside of 2x4 wall plate. NOT flush with siding. Secure the frame by toe nailing into the top plate of the end wall. Use 10d sinkers.
2. Repeat step to install the opposite gable frame.

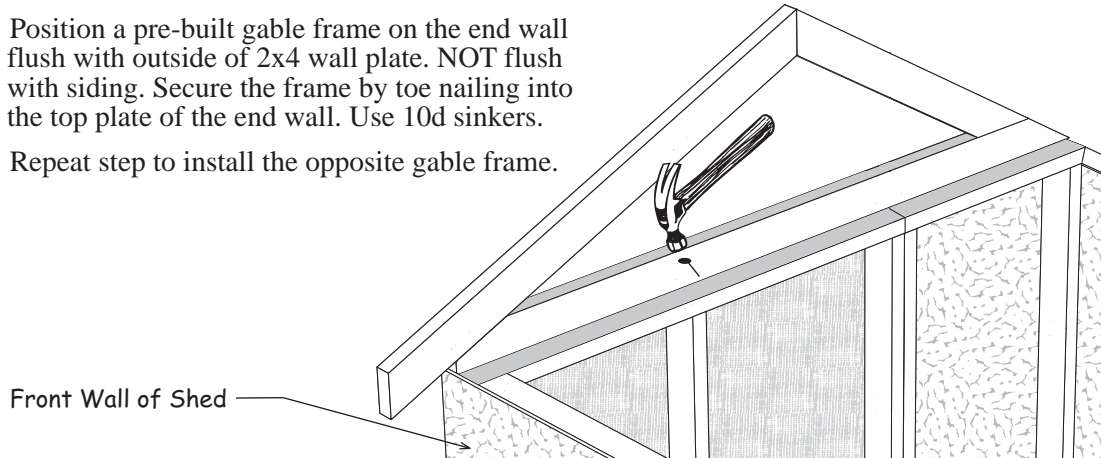

3. Install metal flashing on top of the siding. Nail with a couple of 6d galv. nails to hold the flashing in place until the siding is installed next.
4. Install flashing on opposite wall.

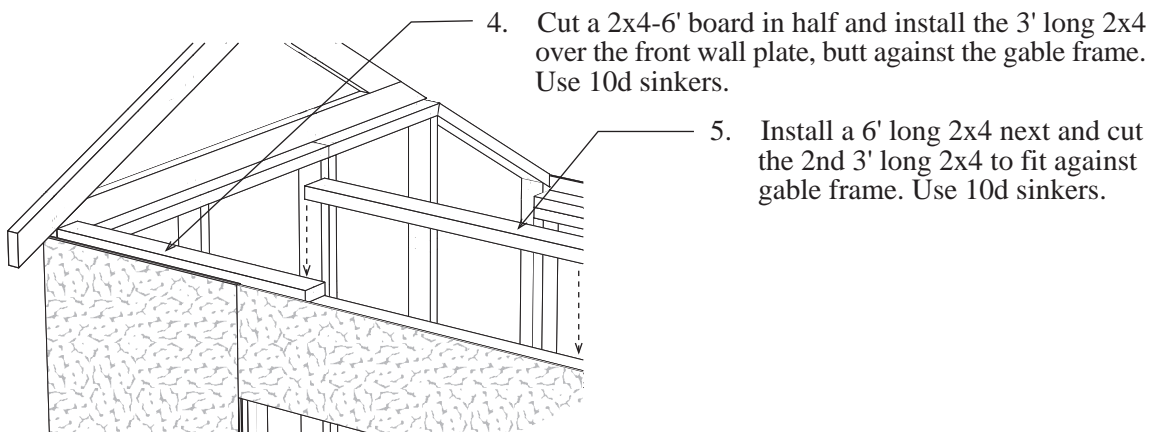
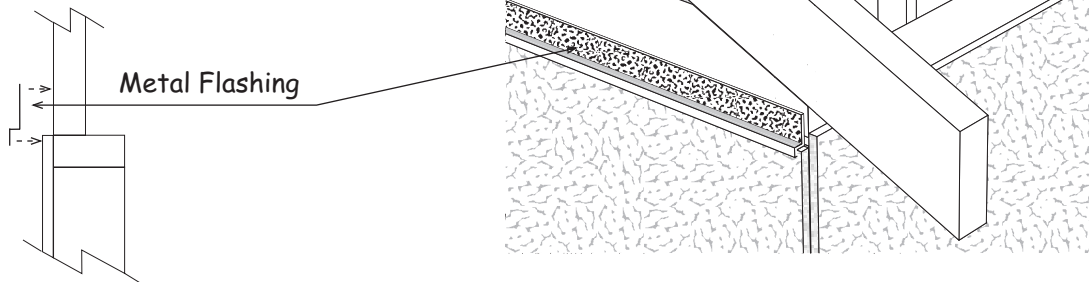

## Step 7 Side Gables

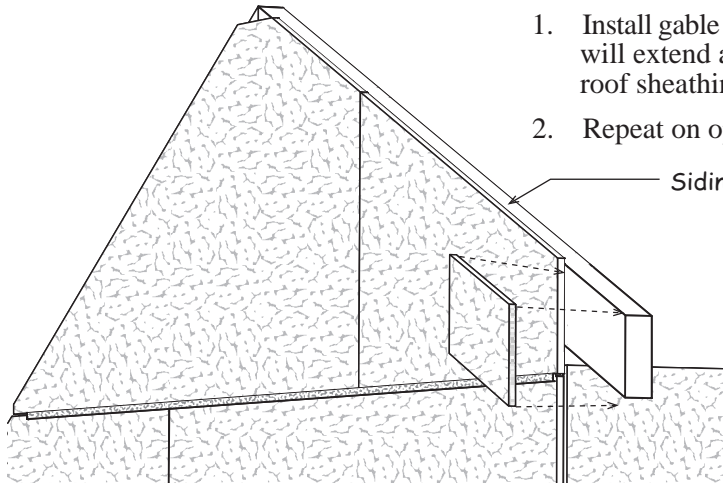

1. Install gable siding using 6d galv. nails. The siding will extend above the gable frame to receive the roof sheathing.
2. Repeat on opposite gable.

Siding Extends 1/2" Above

## Step 8 Set Trusses

1. Install 2x4 roof trusses directly over each wall stud on the back wall. The 3rd truss will be directly over the middle of the double studs. Secure trusses in place with metal truss hangers. Use 6d common nails to secure the metal hanger to the 2x4 wall plates and trusses.

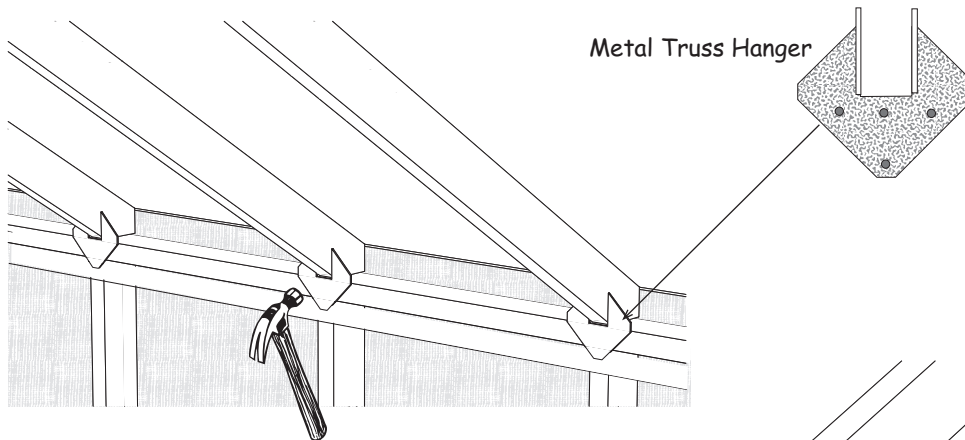

Metal Truss Hanger

2. Secure the trusses to the front wall. Insure trusses are spaced equally from front to back.

Front Wall of Shed

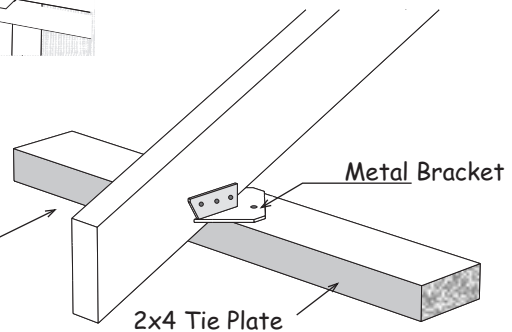

Metal Bracket

2x4 Tie Plate

## Step 9 Install Roof Sheathing

1. Install (2) two 46" x 72" OSB sheathing panels across the front of the roof. Butt 46" edge against back of gable siding. The 72" edge should be flush with the end of the 2x4 truss, *see detail below*. Make sure the trusses are plumb and the roof sheathing meets the center of the 3rd truss. Use 7d sinkers spaced 12" apart. The roof sheathing will be about 1" below the ridge to allow for ventilation if a ridge vent is installed.

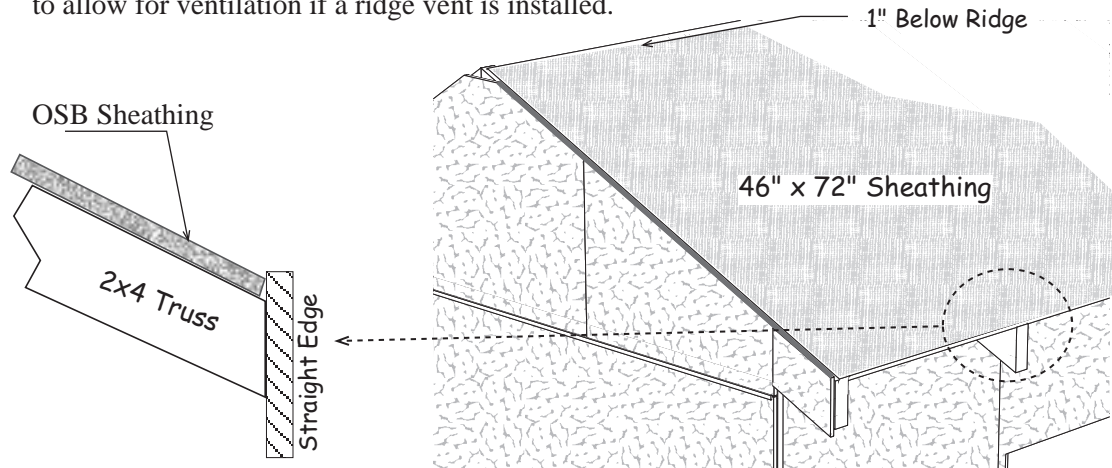

3. Starting in lower left rear corner install (2) one 48" x 72" OSB sheathing across roof. Butt the 48" edge against back of gable siding and position the bottom edge 2-1/2" past back wall siding.
4. Install (3) three 22" x 48" wide roof sheathing across the top of the building. Siding will be about 1" below ridge.

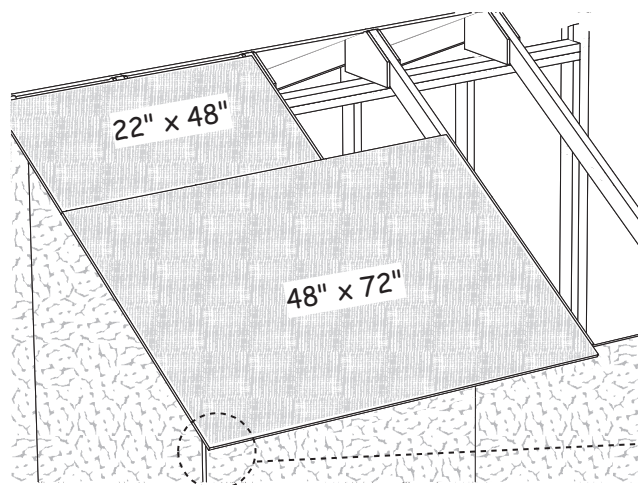

5. Install 60" long 1x3 trim boards on the back wall, flush with the siding on the end wall. Use 8d galv. nails spaced 12" apart.

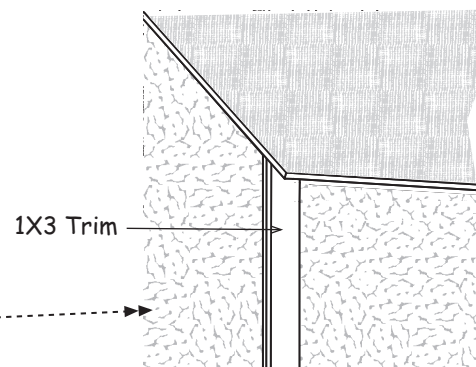

 **STOP! If you purchased the optional metal roofing go to the instructions packaged in the roofing kit. Steps 10, 11 & 12 in this book are skipped.**

## Step 10 Install Soffit and Trim

1. Install 6-1/4" x 48" soffit panels under the truss overhang. Use 6d galv. nails.

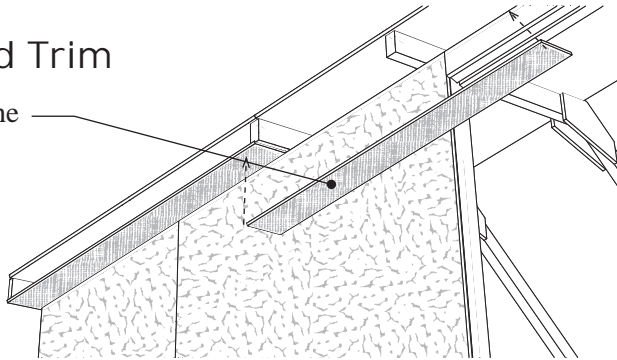

2. Install (1) one 1x4x47-1/4" and (1) one 1x4x72" long gable trim, flush with the top of the roof sheathing on each end wall. Use 8d galv. nails.
3. Install (2) two 77-1/2" long 1x3 trim *on the front corners*, flush with the siding on the sidewall.
4. Install the remaining (4) four 1x4 trim boards at the end wall corners flush with the 1x3 trim on front and back walls.

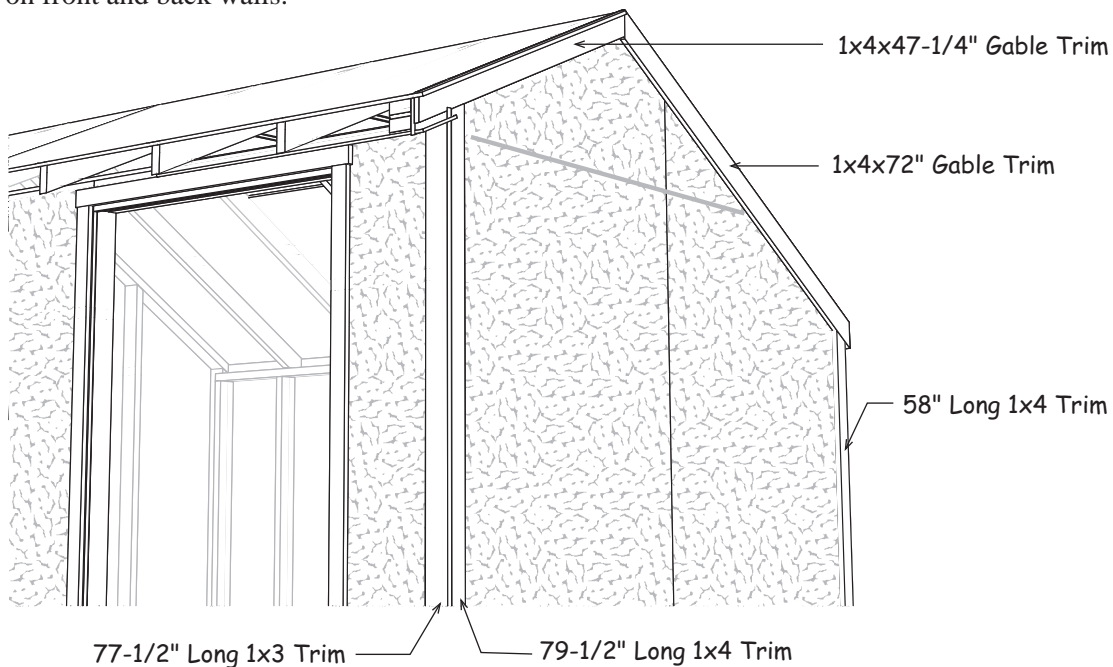

5. Install (2) two 1x3x72" boards along each side of the door opening, flush with the bottom edge of the siding. Tack these boards with a couple nails; you may want to move the trim later when you install the doors. Install a 1x3x55-1/4" board, *that has angle cuts on both ends*, across the top of the side trim. About 3/4" of siding will hang below top trim.

## Step 11 Install Front 1x6 Fascia

1. Install 1x6 fascia over the ends of the trusses, flush with the top of the roof sheathing. Cut a 75" long 1x6 board so to be flush with the face of left wall gable trim and center of 3rd truss. Use 8d galv. nails.
2. Cut to fit the last 1x6x75" board and install to finish.

Top of 1x6 Flush with Top of OSB

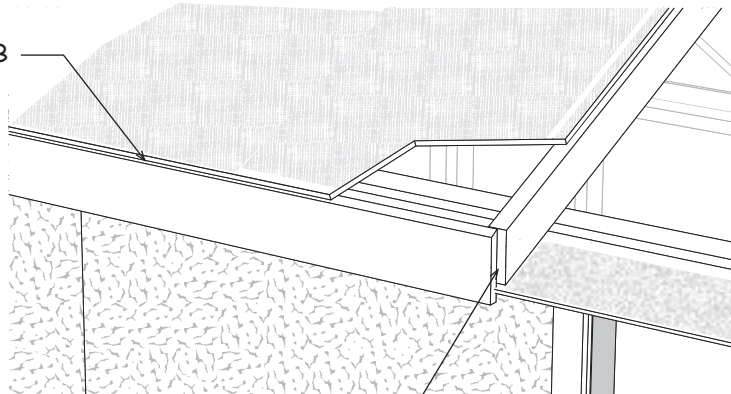

Center of 3rd Truss

## Step 12 Install Roofing — Not Supplied in Kit

1. Install metal roof edging perimeter of the roof area. If you are not installing shingles at this time, you can purchase felt paper to protect the roof sheathing. Install the felt paper before you install the metal roof edge.
2. Install shingles according to the instructions on the wrapper. If you need more detailed instructions on installing shingles, there are good publications at book stores or newsstands.

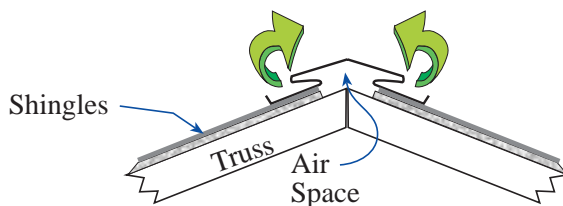
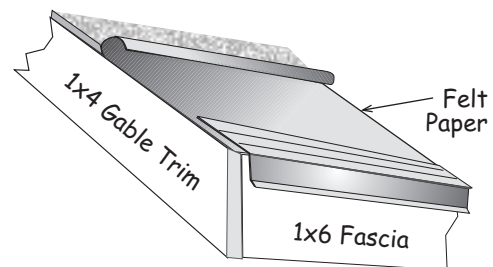

**Building Tip:** Install ridge vent in lieu of shingles caps. Ridge vent provides ideal ventilation, preventing heat and moisture from damaging your building or its contents.

## Step 13 Install Doors

1. Lay the left door with the trim facing up. The 2x4 door stop on the left door extends past the trim. See detail below.
2. Install hinges to the left side of the door frame with 1-1/4" long screws. To position the hinge properly, hold the rectangular plate against the frame.
3. Install hinges to the right side of the other door.

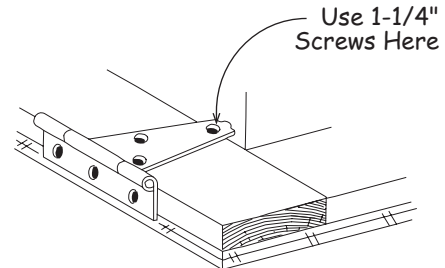

4. Before you fasten the hinges to the door trim, temporarily prop the doors in the opening. Set the door on a piece of OSB, see detail below. Leave a space at the top of the doors and between the doors and the side trim to allow room for the doors to expand when they absorb moisture.

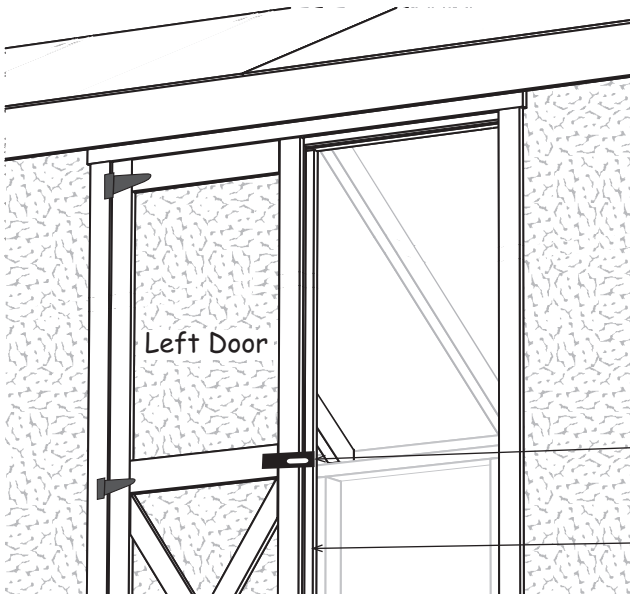

If your door opening is out of square, the space around the doors will not be even. You can remove and reposition the side trim to make allowances for this. The side trim does not have to be flush with the frame of the door opening. You can move the trim in or out to make the door spacing equal.

Secure hinges to door trim with 2" screws.

Install Door Latch  
2x4 Extends Past Trim

5. Install a barrel bolt on the lower back of the door to secure this door in place when closed. You will need to drill a hole for the round shaft to drop into.

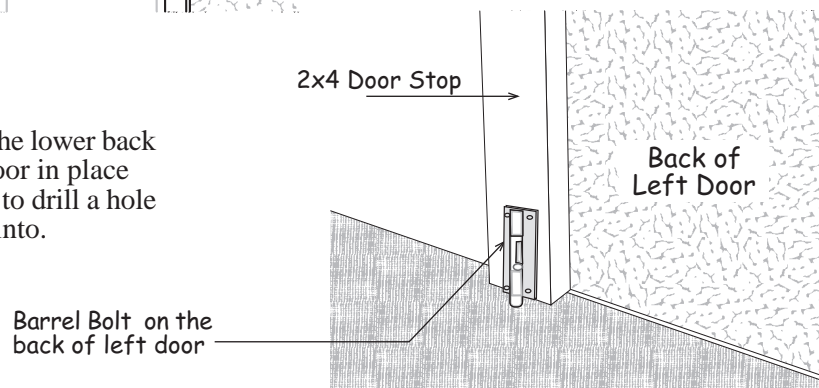

## Aspen II 12' x 8' Shed Kit

 Packing List For Material Shipped on Pallet

Revised February 20, 2018

2x4 Framing & Trim				Hardware						
18	2 x 4	72"	2	1 x 4	79-1/2"	1	Door Latch	2	lb. 10d Sinkers	
5	2 x 4	69-1/2"	2	1 x 4	72"	6	4" Hinges	2	lb. 8d Galv.	
4	2 x 4	68-1/2"	2	1 x 4	47-1/4"	2	6" Barrel Bolt	2	lb. 7d Sinkers	
8	2 x 4	52-7/8"	2	1 x 4	58"	10	H1 - Truss Hangers	1	lb. 6d Common	
4	2 x 4	48"	2	1 x 3	60"	25	2-1/2" Deck Screws	1/2	lb. 6d Galv.	
5	2 x 4	47"	2	1 x 3	72"	2	Z Flashing - 6'	2	Bits for screws	
2	2 x 4	51-1/2"	1	1 x 3	55-1/4"	<b>Miscellaneous Material</b>				
2	2 x 4	13-1/2"	2	1 x 3	77-1/2"	10	Wood Gussets for Trusses	8" x 16"		
2	1 x 6	75"	2	1 x 3	60"	3	LP Primed Soffit Panels	6-1/4" x 48"		
4	2 x 4	77"	Shipped & Attached to Pallet			8	Truss Jig Blocks	1 x 4 - 12"		
Pre-Built Components				LP Primed Siding						
2	Pre-built Wall Panel 48" x 75" w/ Angle Corner			5	48-3/4" x 76-3/4"	1	18-3/4" x 76-3/4"			
2	Pre-built Gable Frames 64-1/4"			3	48-3/4" x 60"	1	48-3/4" x 4-3/4"			
2	Barn Doors 24" x 72"			1	30" x 76-3/4"					
7/16" OSB Sheathing										
2	48" x 72" ( 1 Attached to Pallet)			2	Gable Siding	47" x 19"				
2	46" x 72"		3	22" x 48"	2	Gable Siding	24-3/4" x 14-5/8"			
					2	Gable Siding - End Fillers	5-1/2" x 4-1/2"			

 Packing List For Material Shipped in Metal Roof Kit

3	Metal Roof Panels	36" x 47"	2	Rolls Tytanium Paper	48" x 144"
3	Metal Roof Panels	36" x 72"	1	Roll Tytanium Paper	24" x 144"
2	Metal Gable Trim	2" x 4" x 49-1/2"	1	Roll Screen Ridge Vent	8" x 144"
2	Metal Gable Trim	2" x 4" x 74-1/4"	21	OSB Stripping	4" x 48"
2	Metal Ridge TriCapm	12" x 76"	160	1" Metal Screws & socket	

### Material for Shingling

5 Bundles of Roof Shingles

5 Pieces of 10' Long Roof Drip Edge